

# Progressive scan CCD color camera KP-FR500PCL/SCL Specifications

## 1. General

The KP-FR500PCL/SCL are CameraLink output system progressive scan RAW data output color CCD camera with a 2/3-inch size CCD which adopted the RGB primary color filter and a full frame shutter.

The image of 2456 (H) x 2058 (V) is output in RAW data at 16 frames per second.

The square format picture elements provide suitability for image processing applications.

## 2. Outstanding features

### (1) High resolution and high color fidelity

The 2/3-inch 5,000,000 pixels square lattice progressive scan CCD and the RGB primary color mosaic filter achieve a high resolution and high color fidelity of 2456(H) x 2058(V).

### (2) Small-sized camera

The camera has small SDR connector for digital outputs.

Therefore, the camera has the realization of small-sized shape of 44 (W) x 44 (H) x 41 (D) mm.

### (3) Remote control

- Multi-step electronic shutter (from 1/16 to 1/50000 second in 8 steps)

- Variable shutter (from 10 to 1/100000 second)

- Frame on demand (the image capture at desired timing using the external trigger signal)

and other various functions are set by remote control via CameraLink cable.

### (4) Power over CameraLink

Power supply of KP-FR500PCL is input via CameraLink cable.

(Note: Power supply of KP-FR500SCL is input from DCIN/SYNC connector.)

-	Sep.14,2007	(first edition)	N.Abe	T.Ohsawa
SYMBOL	DATE	DESCRIPTION	(DRAWN)	DESIGNED

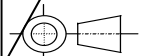
MODEL KP-FR500PCL/SCL				TOLERANCE	Prod. Code - Order No.				
DESIGNED	DATE	APPROVED	DATE	UNIT	TITLE	KP-FR500PCL/SCL Specifications	REV.	0	
CHECKED	DATE	STORED	DATE						SCALE
<b>Hitachi Kokusai Electric</b>									

### 3. Specifications

A	(1) Imaging device	2/3-inch progressive scan interline CCD	A
	Total pixels	2536 (H) x 2068 (V)	
	Effective pixels	2456 (H) x 2058 (V)	
	Pixel size	3.45 um (H) x 3.45 um (V) (square lattice)	
	Color filter	RGB primary color mosaic filter	
	(2) Scanning area	8.47 mm (H) x 7.10 mm (V)	
	(3) Scanning system	Progressive	
B	(4) Aspect ratio	5 : 4	B
	(5) Frame rate	16 frames per second (full pixel readout)	
	(6) Horizontal drive frequency	64.0000 MHz	
	(7) Horizontal scanning frequency	33.264 kHz	
	(8) Vertical scanning frequency	16.00 Hz	
	(9) Sync system	Internal	
	(10) Lens mount	C mount	
	(11) Flange focal distance	17.526 mm	
C	(12) Video output	Digital output (CameraLink)	C
		Base configuration : 64.0000 MHz x 2TAP	
		Medium configuration : 32.0000 MHz x 4TAP	
		Maximum cable length: 10m	
		Output image size: 2456(H) x 2058(V) (full pixel readout)	
	(13) Sensitivity	2000lx, F8, 3200K	
	(14) Minimum illumination	15lx (F1.4 GAIN MAX)	
D	(15) Signal noise to ratio	48dB	D
	(16) Electric shutter	OFF 1/16, 1/60, 1/100, 1/250, 1/1000, 1/2000, 1/10000, 1/50000 second.	
		OFF is normal exposure (frame rate) or changeable by variable shutter (Minimum 1/100000 second)	
	(17) Gamma	= 1	
E	(18) Frame on demand		E
	Mode	(A) Fixed shutter (8steps or variable) (B) ONE trigger mode (C) VD reset mode	
	Trigger input	CameraLink (CC1) or DCIN/SYNC connector	
	(19) Partial scan	Selectable start position and width of picture grabbing in 1H step.	
F	(20) Power supply voltage	12 ± 1 VDC	F
	(21) Current consumption	Approx. 310 mA (Approx. 3.7W) *MAX partial scan 1H: Approx.390 mA (Approx. 4.7W)	

A

(22) Ambient Performance 0 to +40 (+32 to +104 F), less than 90 % RH  
 Operation -10 to +50 (+14 to 122 F), less than 90 % RH  
 Storage -20 to +60 (-4 to 140 F), less than 70 % RH

A

(23) Vibration endurance 10 to 55 Hz (2.37 to 71.7 m/s<sup>2</sup>), sweep: 1 min XYZ 30min  
 (24) Shock endurance 490.3 m/s<sup>2</sup> (Drop test, once each top, bottom, left and right)  
 (25) External dimensions 44 (W) x 44 (H) x 41 (D) mm  
 (Not including mount protrusions)

B

(26) Mass Approx. 110 g

B

(27) Remote control

(a) Signal system

Control system Start-stop synchronization system

Transmission rate 9600 bps

Data length 8 bits

Start bit 1 bit

Stop bit 1 bit

Parity None

Bit transfer LSB first

C

C

(b) Communications control system

Full control by remote control software, data send/receive by text data transfer to camera microprocessor (BSC system handshake)

(c) Control items

1. Shutter speed OFF, 1/16, 1/60, 1/100, 1/250, 1/1000,  
1/2000, 1/10000, 1/50000 second

D

D

Factory setting: OFF

2. Variable shutter 10 to 1/100,000 second

3. Mode OFF, Fixed shutter, ONE trigger mode

and VD reset mode Factory setting: OFF

4. Gain 0 to 12 dB(Approx. 0.0358 dB step)

Factory setting: 0 dB

5. VD/FVAL Factory setting: FVAL

6. HD/LVAL/LVAL2 Factory setting: LVAL

7. 8bit/10bit/12bit Factory setting: 8bit

8. Partial scan Factory setting: OFF

9. Offset level

10. Trigger pulse polarity Factory setting: POS

11. Base/Medium configuration Factory setting: Base

12. Trigger input CameraLink (CC1) or DCIN/SYNC connector

Factory setting: CC1

F

F

13. Output signal OFF, FLASH OUT and VD OUT Factory setting: OFF

#### 4. Composition

- (1) Camera (with IR cut filter)
- (2) CD-ROM(Operation manual, Control software)
- (3) Composition table

#### 5. Optional accessories

- (1) Dummy glass (AR coated)                      ARC1214
- (2) IR cut filter    IRC650
- (3) Junction box    JU-F30,
- (4) Tripod adaptor    TA-F500
- (5) 12pin plug    HR10A-10P-12S(01)
- (6) Camera cable

	Molded type	Shield type
2 m	C-201KSM	C-201KSS
5 m	C-501KSM	C-501KSS
10 m	C-102KSM	C-102KSS

In the CE Marking region, use the shield type and install clamp filter (ZCAT2035-0930A: TDK) at both ends of the cable.

#### (7) Digital out cable

- Mini CameraLink cable (for KP-FR500SCL) SDR-MDR type

Cable length	Model name
1m	C-101SCL
2m	C-201SCL
3m	C-301SCL
5m	C-501SCL
10m (for High frequency)	C-102SCL (HF)

- PoCL cable (for KP-FR500PCL)

Cable length	Model name	
	SDR-SDR type	SDR-MDR type
1m	C-101PCL (SS)	C-101PCL (SM)
2m	C-201PCL (SS)	C-201PCL (SM)
3m	C-301PCL (SS)	C-301PCL (SM)
5m	C-501PCL (SS)	C-501PCL (SM)

SDR: Shrunken Delta Ribbon

MDR: Miniature Delta Ribbon

## 6. Specification of Digital output connector

### (1) Signal connection to DC IN/SYNC

PIN No.	Internal SYNC mode	PIN No.	Internal SYNC mode
1	GND	7	Trigger IN / VD IN
2	---- (KP-FR500PCL)	8	GND
	+12V(KP-FR500SCL)		
3	GND	9	----
4	----	10	FLASH OUT / VD OUT
5	GND	11	----
6	----	12	GND

Plug (matching cable plug) Hirose HR10A-10P-12S(01) or equivalent

(Note) Please do not unplug and insert cable (camera cable) with a power supplied to a camera.  
Install clamp filter (ZCAT 2035-0930A: TDK) at both ends (camera and video processor ends) in the CE marking region.

## (2) Signal connection to DIGITAL OUT connector

## D.OUT 1 (Connector 1)

Pin No.	Signal	Pin No.	Signal
1	+12V (KP-FR500PCL)	14	GND
	GND (KP-FR500SCL)		
2	TXOUT 0 (-)	15	TXOUT 0 (+)
3	TXOUT 1 (-)	16	TXOUT 1 (+)
4	TXOUT 2 (-)	17	TXOUT 2 (+)
5	TXCLKOUT (-)	18	TXCLKOUT (+)
6	TXOUT 3 (-)	19	TXOUT 3 (+)
7	RX (+) [ SERTC (+) ]	20	RX (-) [ SERTC (-) ]
8	TX (-) [ SERTFG (-) ]	21	TX (+) [ SERTFG (+) ]
9	TRIG/VD (-) [ CC1 (-) ]	22	TRIG/VD (+) [ CC1 (+) ]
10	N.U. [ CC2 (+) ]	23	N.U. [ CC2 (-) ]
11	N.U. [ CC3 (-) ]	24	N.U. [ CC3 (+) ]
12	N.U. [ CC4 (+) ]	25	N.U. [ CC4 (-) ]
13	GND	26	+12V (KP-FR500PCL)
			GND (KP-FR500SCL)

## D.OUT 2 (Connector 2)

Pin No.	Signal	Pin No.	Signal
1	+12V (KP-FR500PCL)	14	GND
	GND (KP-FR500SCL)		
2	TYOUT 0 (-)	15	TYOUT 0 (+)
3	TYOUT 1 (-)	16	TYOUT 1 (+)
4	TYOUT 2 (-)	17	TYOUT 2 (+)
5	TYCLKOUT (-)	18	TYCLKOUT (+)
6	TYOUT 3 (-)	19	TYOUT 3 (+)
7	N.U.	20	N.U.
8	N.U.	21	N.U.
9	N.U.	22	N.U.
10	N.U.	23	N.U.
11	N.U.	24	N.U.
12	N.U.	25	N.U.
13	GND	26	+12V (KP-FR500PCL)
			GND (KP-FR500SCL)

Connector (camera side) SDR connector (Sumitomo 3M) or equivalent N.U.: Not used

- D.OUT2 is used for Medium configuration.
- The digital out cable should be comprised of a twisted pair of wires having 100 ohm characteristic impedance and an outer sheath shield type conductor.
- Connect the shield (ground) of the digital out cable to the ground terminal of the video equipment, frame grabber, etc.
- Install clamp filter (ZCAT2035-0930A: TDK) at both ends (camera and video processor ends) in the CE marking region.
- TX: Transmit data from camera to machine
- RX: Transmit data from machine to camera

(Note) Please do not unplug and insert cable (digital out cable)  
with a power supplied to a camera.

### 7. CamraLink output

A

#### 7-1. Horizontal timing

A

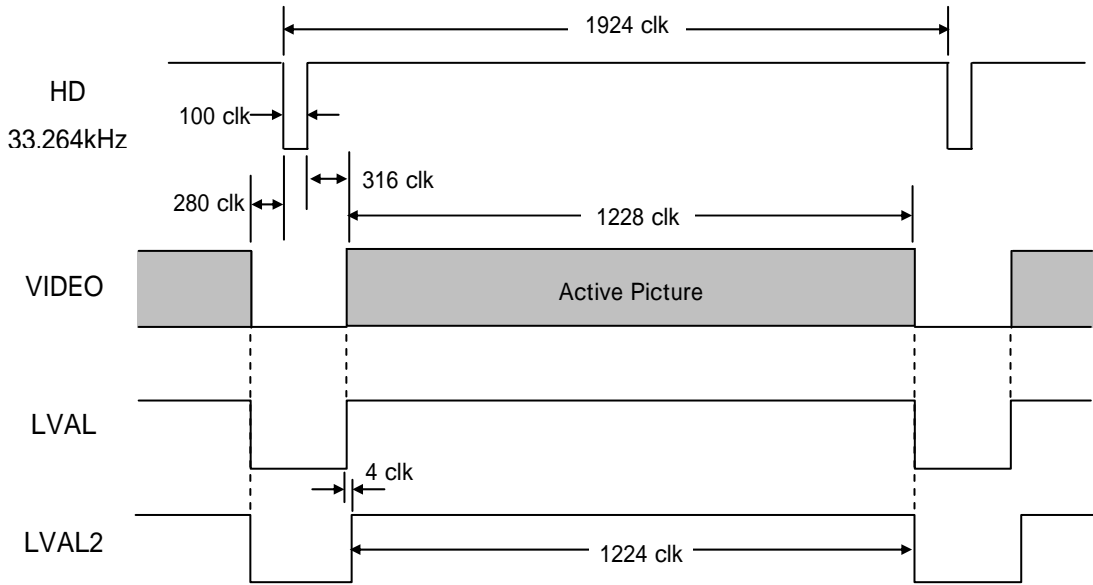

B

C

1clk = 15.63ns (64.0000MHz)

#### 7-2. Vertical timing

D

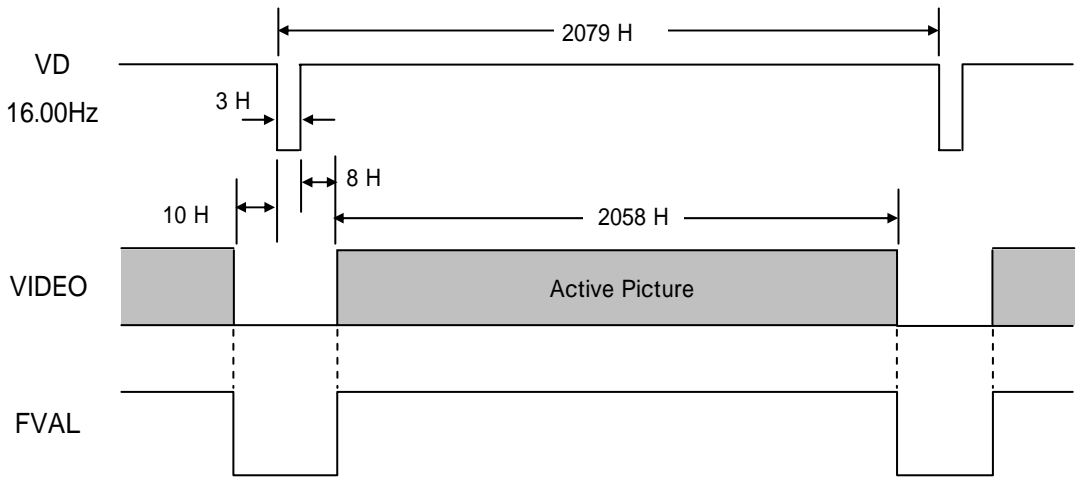

D

E

1H = 1924clk = 30.06 μs

F

F

### 7-3. Transmitter LVDS output pulse position measurement

#### (1) Base configuration

##### (A) 8bit

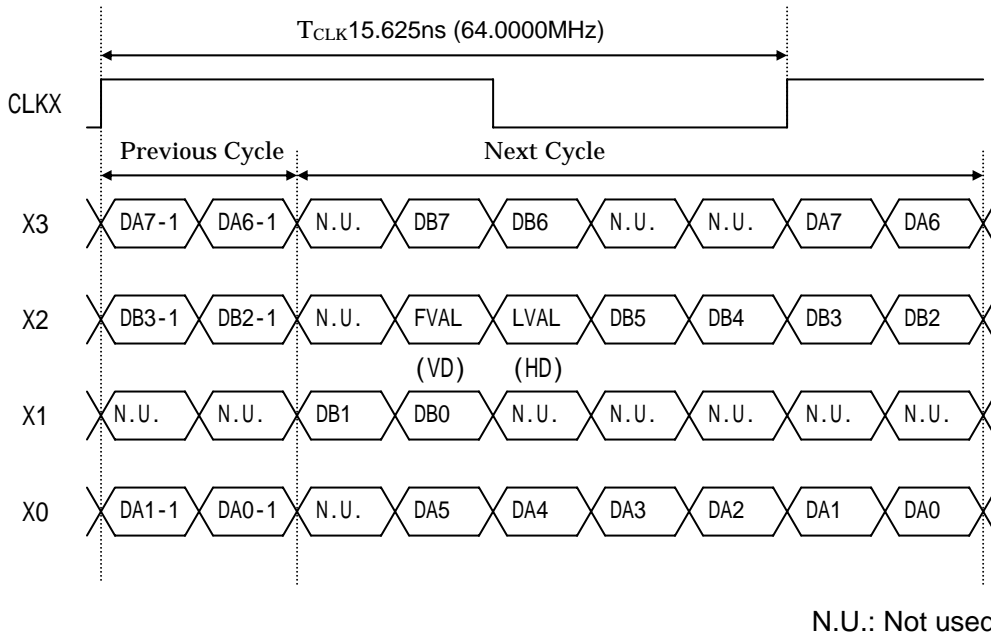

##### (B) 10bit

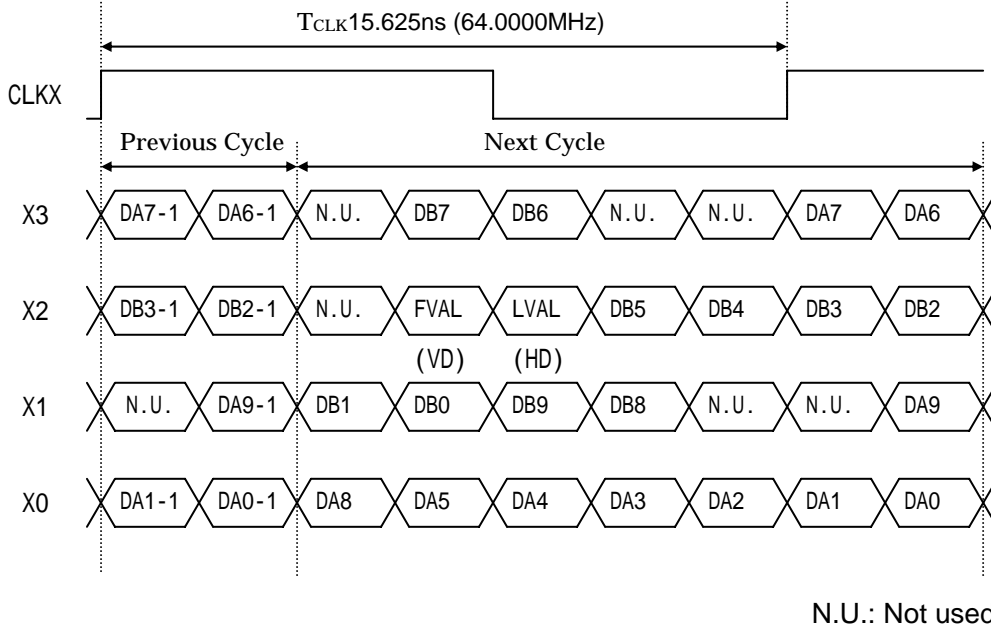

(C) 12bit

A

B

C

D

E

F

A

B

C

D

E

F

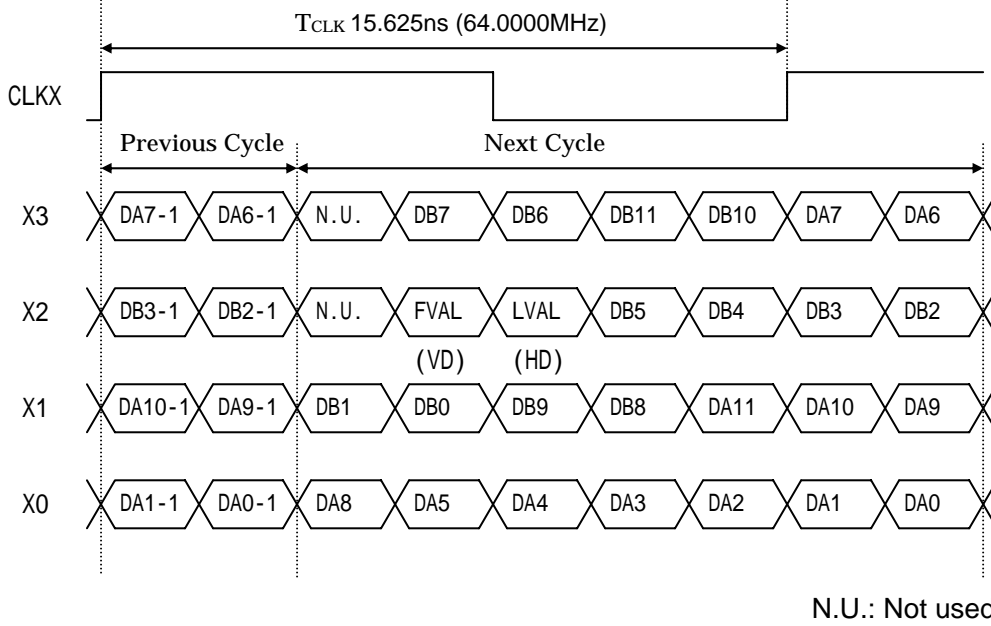

\* When using Base configuration, please be sure to connect to CameraLink cable to D.OUT1.  
 If the cable is connected to D.OUT2, the machine may break down.

(2) Medium configuration

(A) 8bit

D.OUT 1

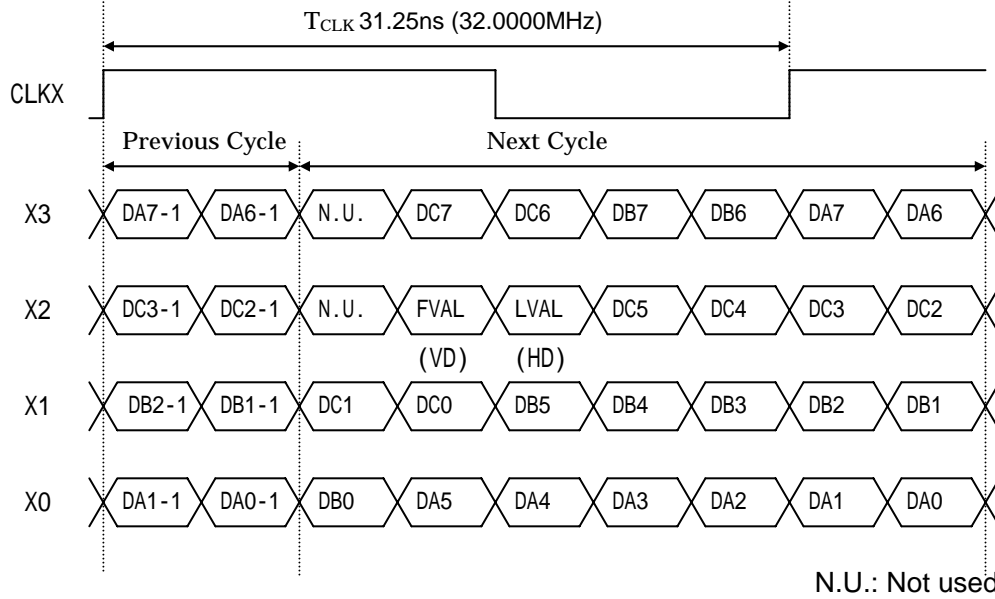

D.OUT 2

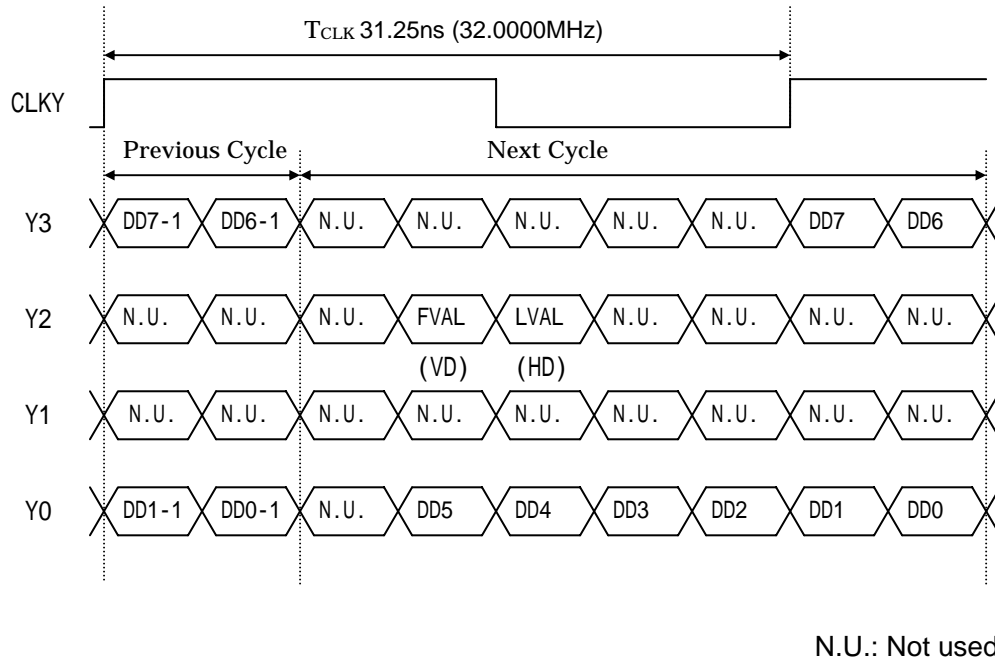

(B) 10bit

D.OUT 1

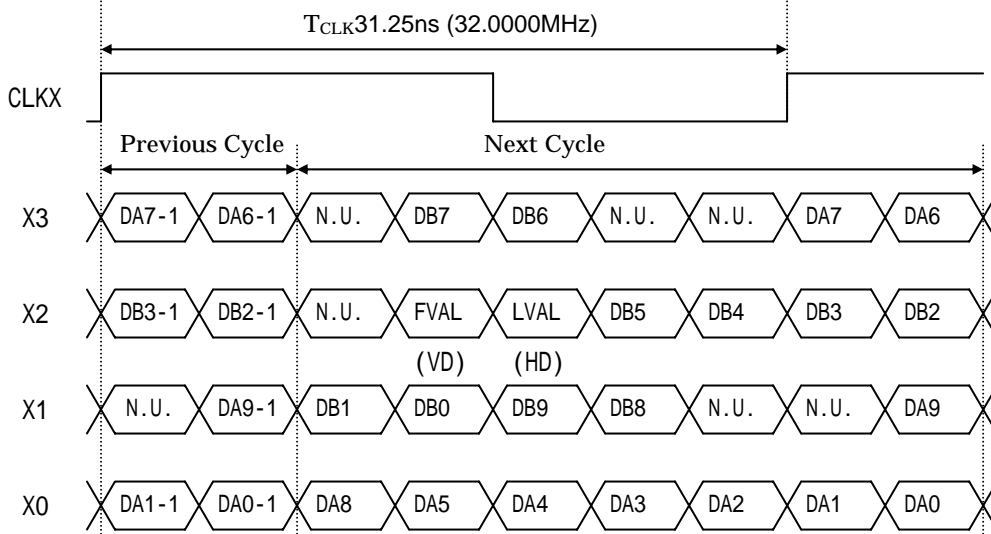

N.U.: Not used

D.OUT 2

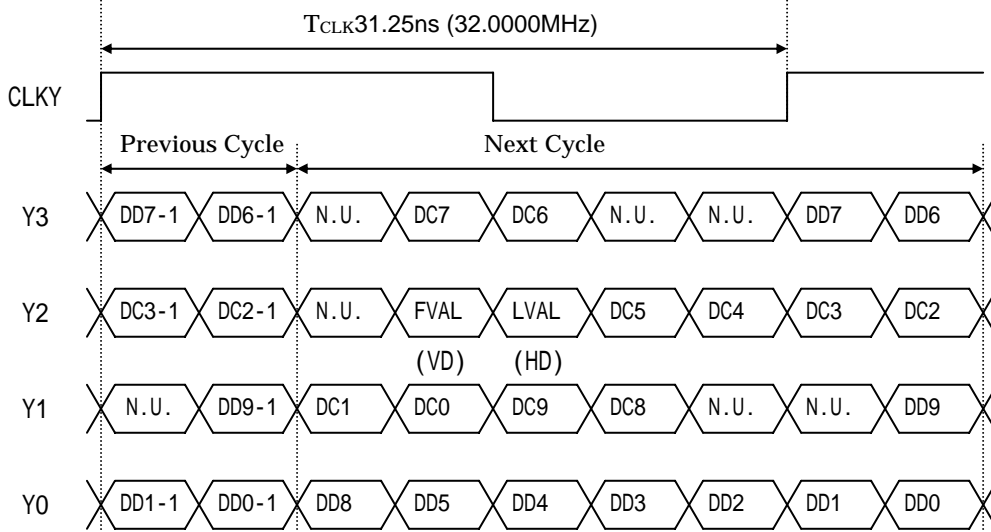

N.U.: Not used

(C) 12bit

D.OUT 1

A

A

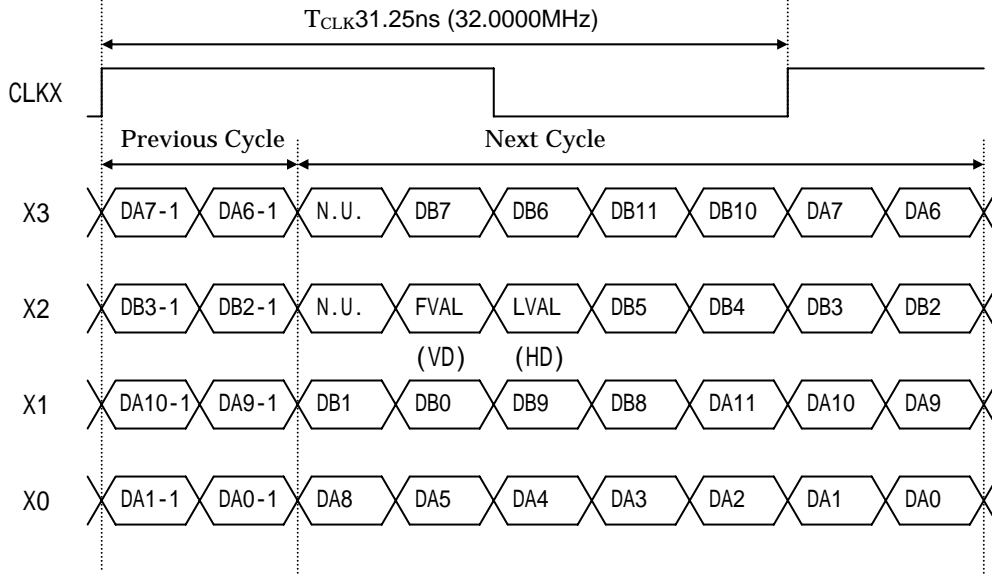

N.U.: Not used

C

C

D.OUT 2

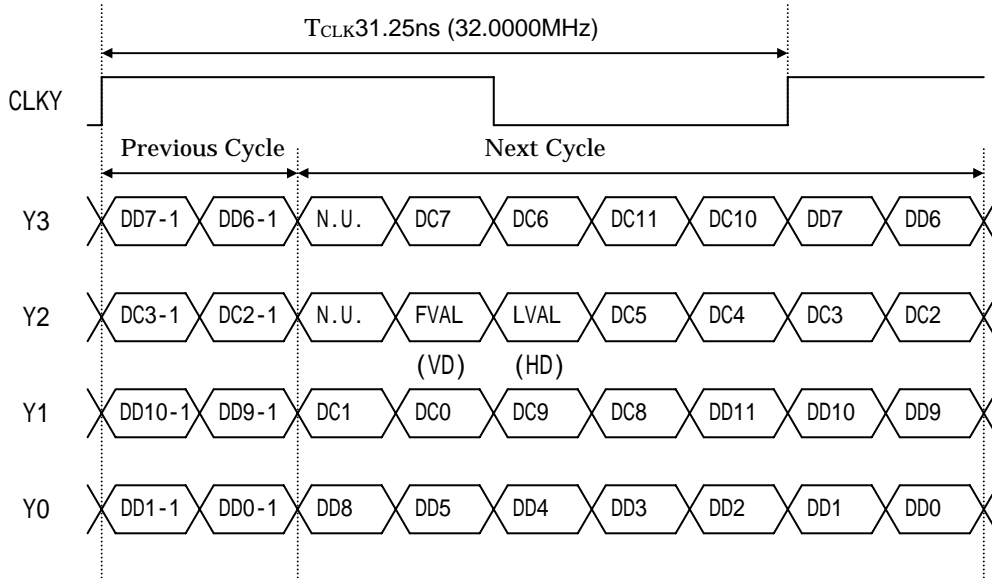

N.U.: Not used

E

E

F

F

7-4. RAW data output sequence

$X = H/2$

$H = 2456$

$V = 2058$

(A) Base configuration

R(DA) G(DA) B(DA) : Data of screen left half. These mean R component, G component and B component.

R(DB) G(DB) B(DB) : Data of screen right half. These mean R component, G component and B component.

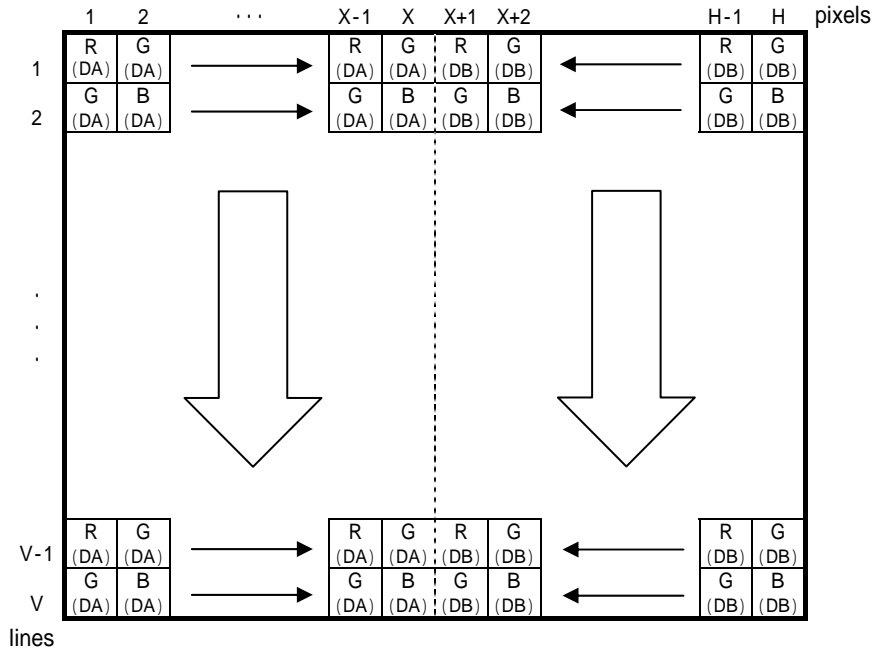

(B) Medium configuration

R(DA) G(DA) G(DB) B(DB) : Data of screen left half. These mean R component, G component and B component.

R(DD) G(DC) G(DD) B(DC) : Data of screen right half. These mean R component, G component and B component.

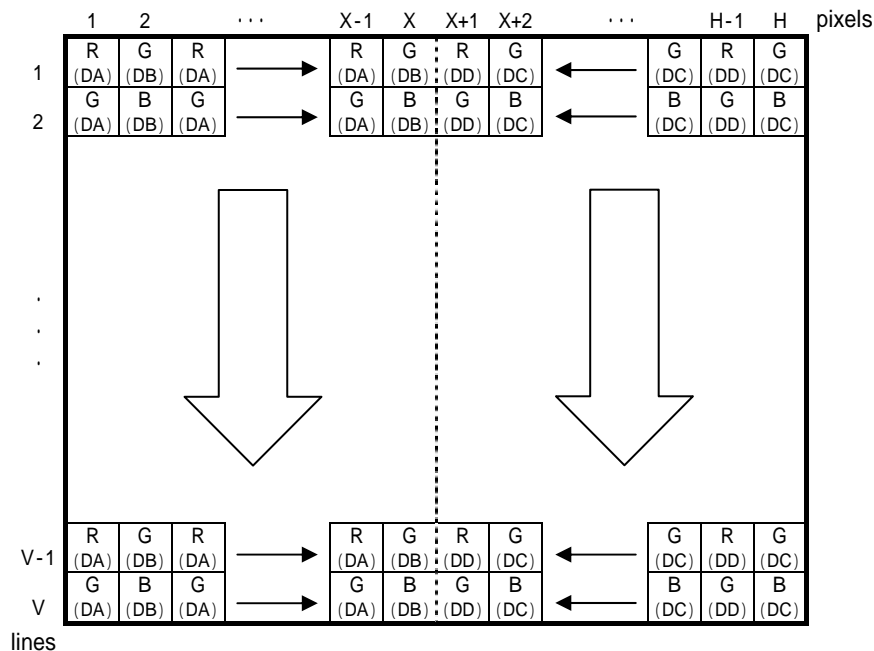

# 8. Timing chart

## 8-1. Normal mode

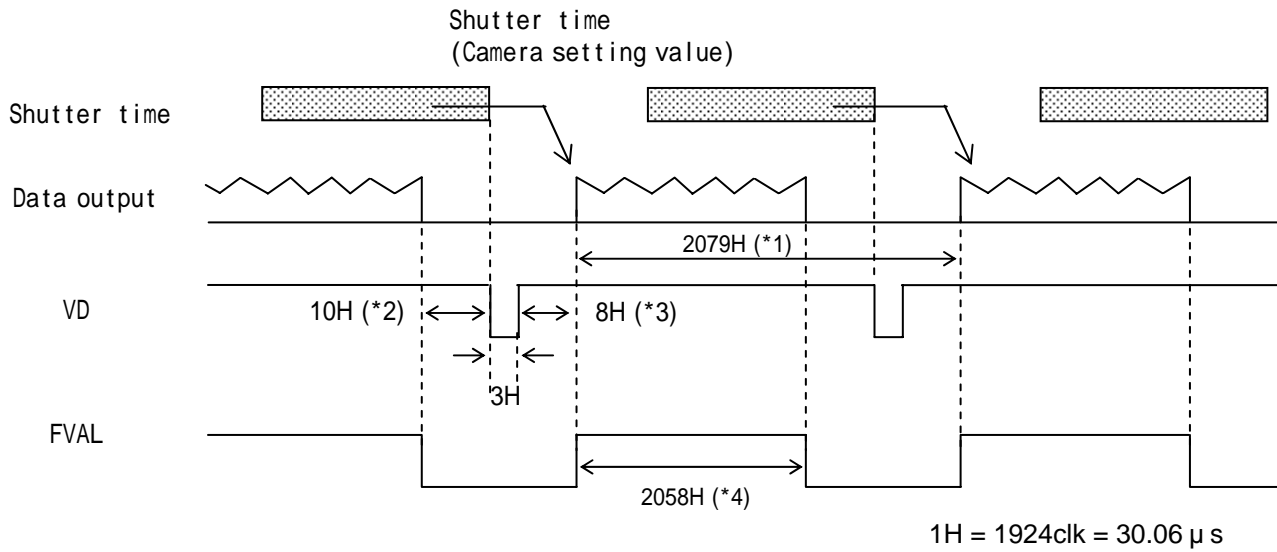

When partial scan is ON, \*1 to \*4 are variable by start position of picture grabbing and width of picture grabbing (omit the figures after the decimal fractions).

\*1:  $(14 + \text{Width} + (2067 - \text{Width}) / 4)H$

\*2:  $(3 + (2067 - \text{Width}) / 4 - \text{Start} / 4)H$

\*3:  $(8 + \text{Start} / 4)H$

\*4:  $(\text{Width})H$

Note1: Please use the partial scan in following condition.

$$\text{Start} + \text{Width} \leq 2059$$

Note2: Please use FVAL in the partial scan.

Graph following shows frame rate in each width of picture grabbing when partial scan is ON.

KP-FR500PCL/SCL Partial scan

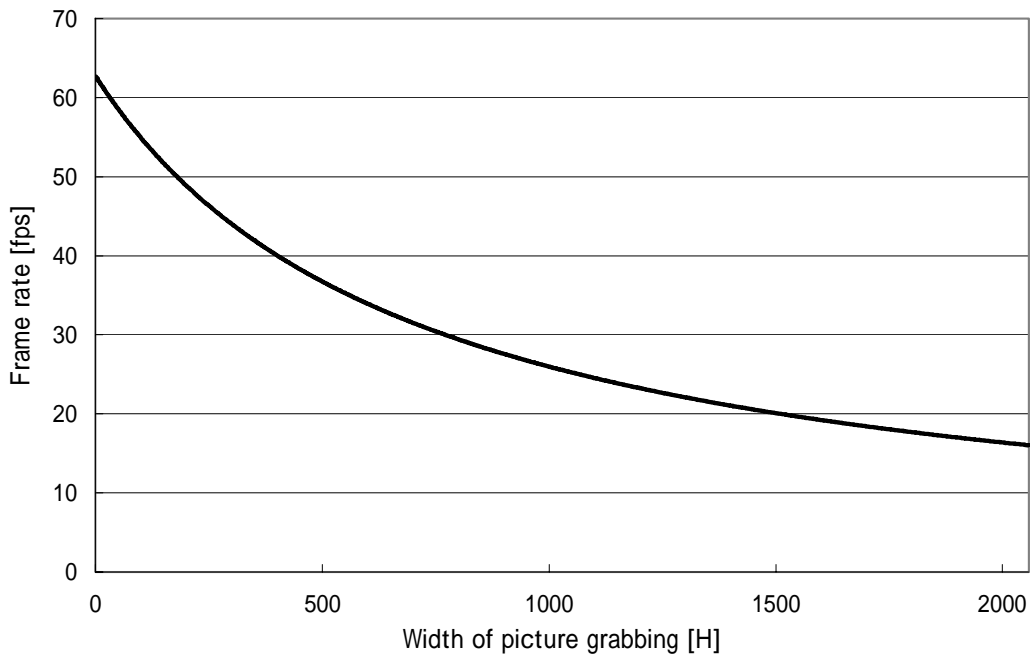

Note: Frame rate can be calculated from following equations using width of picture grabbing.

$$\text{Lines} = 14 + \text{Width} + (2067 - \text{Width}) / 4$$

$$\text{Frame rate} = (64000000 / 1924) / \text{Lines}$$

DWG.  
No.

**E400082401**

SHEET  
14 /  
20

### 8-2. Fixed shutter mode

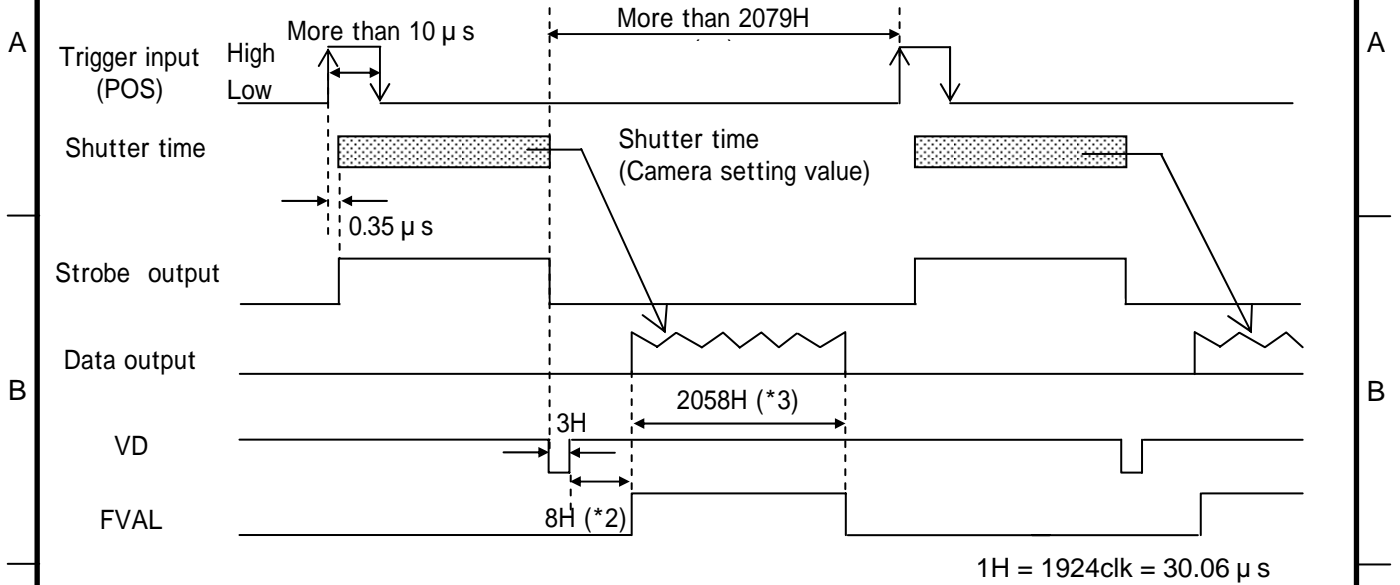

When partial scan is ON, \*1 to \*3 are variable by start position of picture grabbing and width of picture grabbing (omit the figures after the decimal fractions).

- \*1:  $(14 + \text{Width} + (2067 - \text{Width}) / 4)H$  or more
- \*2:  $(8 + \text{Start} / 4)H$
- \*3:  $(\text{Width})H$

Note1: Please use the partial scan in following condition.  
 $\text{Start} + \text{Width} \leq 2059$

Note2: Please use FVAL in the partial scan.

### 8-3. ONE trigger mode

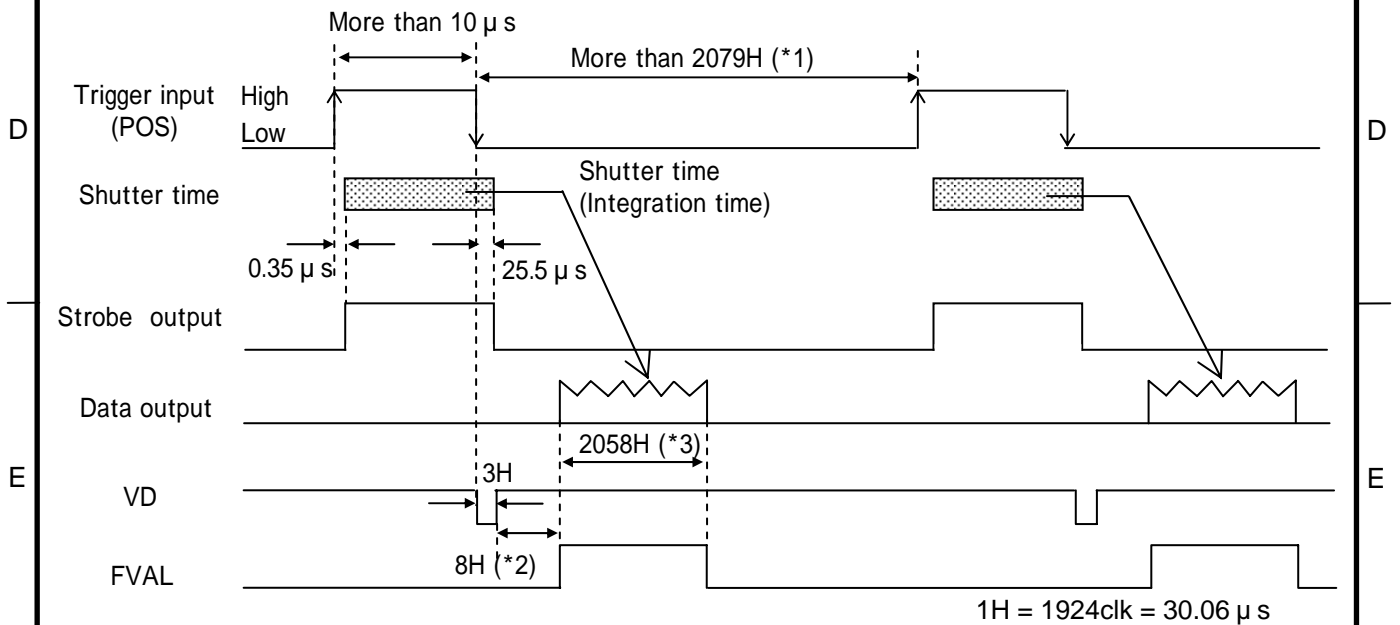

When partial scan is ON, \*1 to \*3 are variable by start position of picture grabbing and width of picture grabbing (omit the figures after the decimal fractions).

- \*1:  $(14 + \text{Width} + (2067 - \text{Width}) / 4)H$  or more
- \*2:  $(8 + \text{Start} / 4)H$
- \*3:  $(\text{Width})H$

Note1: Please use the partial scan in following condition.  
 $\text{Start} + \text{Width} \leq 2059$

Note2: Please use FVAL in the partial scan.

8-4. VD reset mode

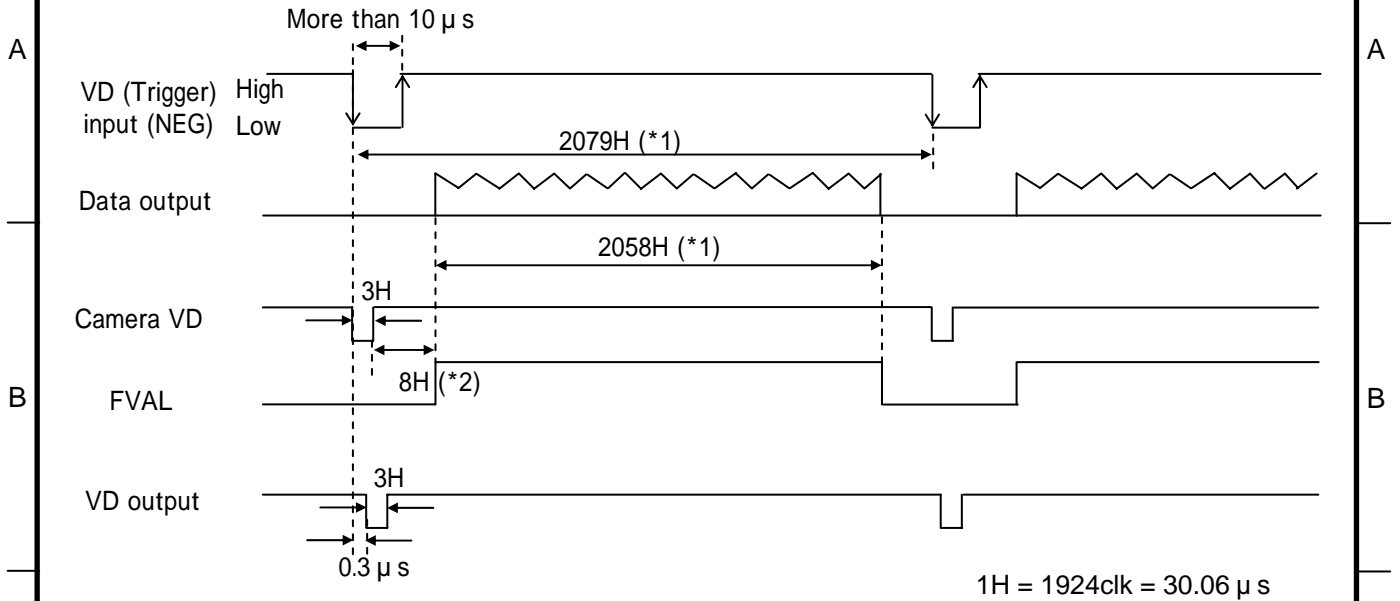

When partial scan is ON, \*1 to \*3 are variable by start position of picture grabbing and width of picture grabbing (omit the figures after the decimal fractions).

\*1:  $(14 + Width + (2067 - Width) / 4)H$

\*2:  $(8 + Start / 4)H$

\*3:  $(Width)H$

Note1: Please use the partial scan in following condition.

Start + Width 2059

Note2: Please use FVAL in the partial scan.

NOTE: If the external VD of cycle which does not match the camera operation mode is input, shutter time has an error.

9. Spectral response

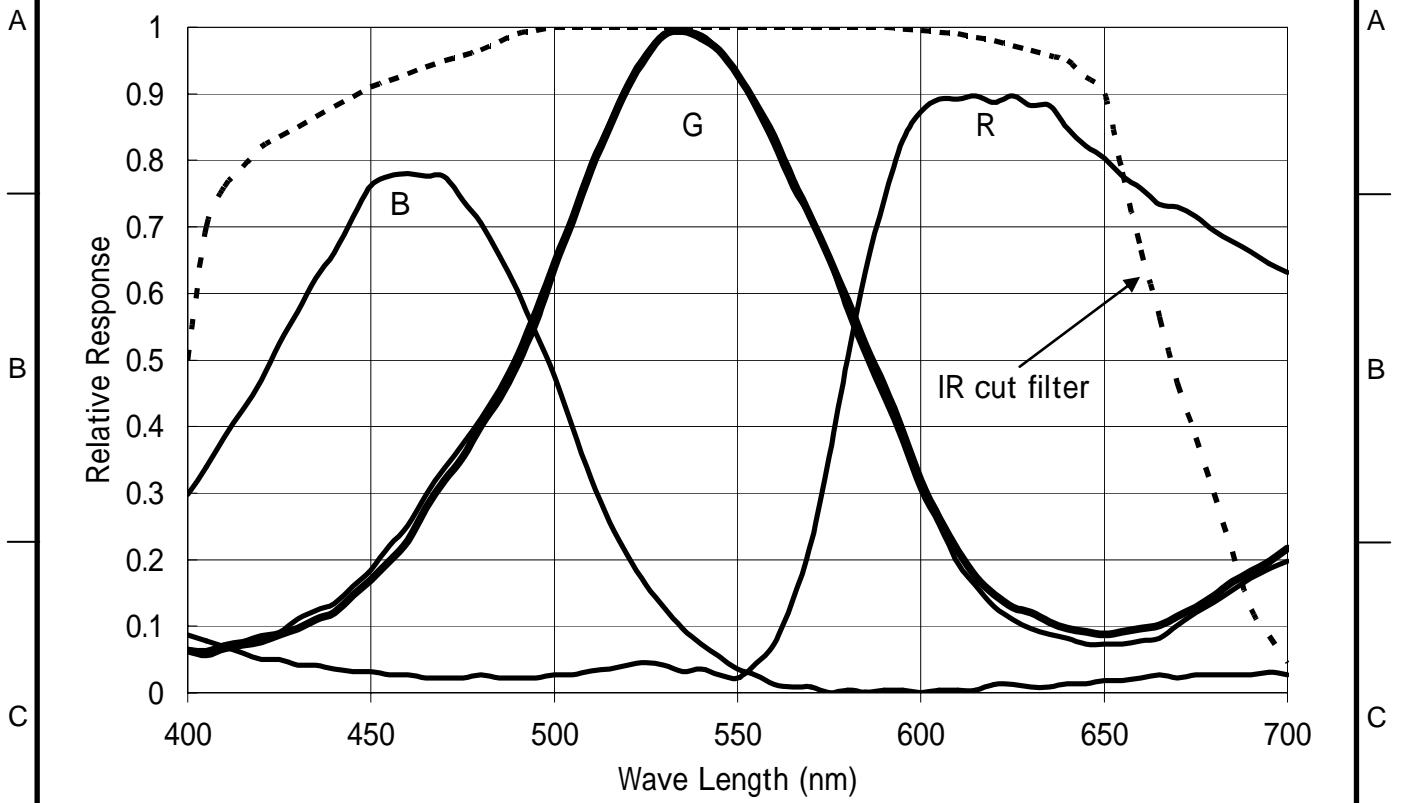

10. External view

- MASS : APPROX 110 g
- UNIT : mm
- SCALE : NTS

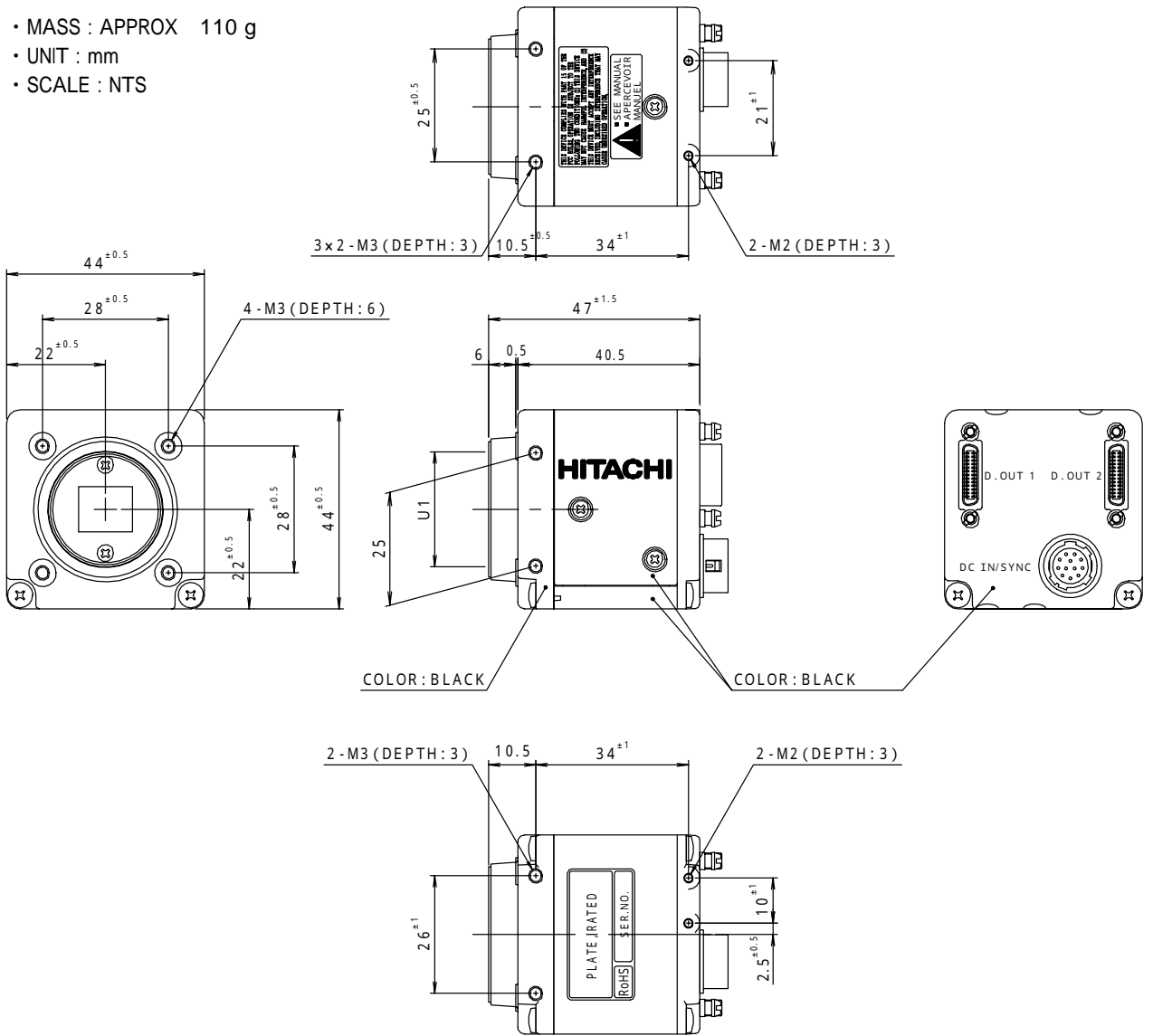

**Notice:**

These specifications are subject to change without prior notice due to product improvement.

Confirm the most recent specifications at time of order.

Hitachi Kokusai certifies this product complies with the standard warranty conditions of Hitachi Kokusai, and that quality control is implemented to the extent required to comply with these conditions.

**RoHS Compliant**

This product complies with the requirement of the RoHS(Restriction of the use of Certain Hazardous Substances in Electrical and Electronic Equipment) Directive 2002/95/EC

**Warranty and service:**

- (1) The guarantee period is one year after the data purchase.  
However, the defects due to erroneous use or intentional act are excluded.
- (2) As the defect after expiration of the guarantee period, where product repair is possible, repair will be performed at charge.
- (3) The present Warranty pertains only to the camera unit. Secondary malfunctions attributable to camera failure as well as expenses incurred by disassembly and reassembly of the related system, are beyond the scope of this Warranty.
- (4) Compensation for loss of business, loss or damage to software, database and other contingent losses are beyond the scope of this Warranty.
- (5) Hitachi Kokusai Electric Inc. is not liable for the losses caused when the equipment is used in a system, use for business trades, production process, medical fields, crime prevention applications, etc.
- (6) In the case of camera trouble by miss wiring of cable, it will be considered as out of warranty.

