

Gigabit Ethernet

Progressive Scan CCD Camera

KP-FD500GV

Specifications Ver.1.00

1. General

The KP-FD500GV is single CCD type RGB color camera which utilized the progressive scan CCD image sensor with square pixel for SXGA format of 2/3-inch which adopted the RGB primal color mosaic filter. By adoption of Gigabit Ethernet interface, high-speed connection of maximum of 1 Gbps can be possible. Moreover, by using hub or switcher, construction of multiple camera system can be easily performed.

2. Outstanding features

(1) High resolution and color fidelity

The 2/3-inch 5,010,000 pixels square lattice progressive scan CCD and the RGB primary color mosaic filter achieve a high resolution and high color fidelity of 2448(H) x 2050(V).

(2) Gigabit Ethernet interface

High-speed serial interface Gigabit Ethernet is supported and direct connection is possible to PC by the diameter cable of thin as compared with parallel output. It is possible to 100m.

(3) GigE Vision (Ver. 1.00) correspondence

Based on Industrial camera interface standard GigE Vision, a maximum of 1Gbps high speed data transmit is available and suitable for image processing.

(4) GENiCAM (Ver. 1.00) correspondence

Development of camera control system is easy because industrial camera control API "GENiCAM" lead EMVA (European Machine Vision Association).

(5) PoE correspondence

Power supply can be input via Ethernet cable (Power over Ethernet).

(6) Remote control

- Multi-step electronic shutter (from 1/9 to 1/50000 second in 8 steps)
 - Variable shutter (from 10 to 1/100000 second)
 - The image capture at desired timing using the external trigger signal
 - White balance (ATW, Manual and One-push)
 - 6 color independent masking (R, G, B, Cy, Mg, Ye can be independently varied)
- and other various functions are set by remote control via a Gigabit Ethernet cable.

GigE Vision™ and the distinctive logo are trademarks of AIA (Automated Imaging Association).

GENiCAM™ is a trademark of EMVA (European Machine Vision Association).

Ethernet is a trademark of XEROX Corporation.

Hitachi Kokusai Electric

3. Specifications

(1) Imaging device	2/3-inch progressive scan interline CCD
Total pixels	2536 (H) x 2068 (V)
Effective pixels	2456 (H) x 2058 (V)
Pixel size	3.45 um (H) x 3.45 um (V) (square lattice)
Color filter	RGB primary color mosaic filter
(2) Scanning area	8.45 mm (H) x 7.07 mm (V)
(3) Scanning system	Progressive
(4) Aspect ratio	5 : 4
(5) Frame rate	7 frames per second (full pixel readout RGB 8bit)
(6) Sync system	Internal / external
(7) Lens mount	C mount
(8) Flange focal distance	17.526 mm
(9) Video output	
Interface	Gigabit Ethernet
Protocol	GigE Vision compliant
Transfer	1 Gbit per second
Image format	RGB 8/10/12bit YUV(4:2:2) 8/10/12bit RAW 8/10/12bit Mono 8/10/12bit
Maximum image size	2448 (H) x 2050 (V)
Frame rate	9 frame per second *Frame rate is different for following format RGB 8bit: 7 frame per second RGB 10bit: 5 frame per second RGB 12bit: 3 frame per second YUV 10bit: 7 frame per second YUV 12bit: 7 frame per second
(10) Sensitivity	2000lx, F11, 3200K
(11) Minimum illumination	5 lx (F1.4 GAIN MAX)
(12) Electric shutter	OFF / Auto (AES) / Manual (PRESET or VARIABLE) OFF is normal exposure (frame rate)
PRESET	1/9, 1/60, 1/100, 1/250, 1/1000, 1/2000, 1/10000, 1/50000 second.
VARIABLE	10 to 1/100000 second

- (13) External trigger shutter
- | | |
|----------------|--|
| Mode | Fixed shutter
One trigger
VD Sync
Reset control |
| Input | Via Gigabit Ethernet cable (Software trigger)
12-pin connector (Hardware trigger) |
| Input level | 24Vp-p +/- 1V |
| Threshold | 3.7V +/- 0.5V (Low --> High)
3.3V +/- 0.5V (High --> Low) |
| Input polarity | High / Low adjustable |
| Input delay | Adjustable |
- (14) External sync signal
- | | |
|-----------------|-----------------------|
| VD output | 5Vp-p +/- 0.3V |
| Strobe out | 5Vp-p +/- 0.3V |
| Output polarity | High / Low adjustable |
| Strobe delay | Adjustable |
| Strobe duration | Adjustable |
- (15) Partial scan Selectable start position and width of picture grabbing in 2H step.
- (16) ALC (Auto level control) Adjustable for video level
- (17) White balance ATW / MANUAL / One-push
- (18) Gain Auto / Manual (0dB to 12dB)
- (19) Gamma OFF ($\gamma=1$) / ON
- (20) Color masking OFF / ON (6 vector independent masking)
- (21) Paint black Adjustable
- (22) Sharpness Adjustable
- (23) Black level Adjustable
- (24) Knee Adjustable
- (25) Power supply voltage DC+12V +/- 1V (input from 12-pin connector)
48V (PoE)
- (26) Current consumption Approx. 7.4W (DC+12V)
When partial scan is on, Max Approx. 7.8W (DC+12V)
- (27) Ambient
- | | |
|-------------|---|
| Performance | 0 to +40°C (+32 to +104 F), less than 90 % RH |
| Operation | -10 to +50°C (+14 to +122 F), less than 90 % RH |
| Storage | -20 to +60°C (-4 to +140 F), less than 70 % RH (without dew condensation) |
- Note : If operated continuously, be sure to use at less than +40°C (+104F)
for long term stable performance.
- (28) Vibration endurance 98.6 m/s² or less (10 to 200 to 15Hz, 30 minutes each on XYZ axes)
(Do not subject to strong vibration for long periods of time.)
- (29) Shock endurance 490.3 m/s² (Drop test, once each top, bottom, left and right)
- (30) External dimensions 44(W) x 29(H) x 72(D) mm (not including protrusions)
- (31) Mass Approx. 140g

6. Specification of Digital output connector

(1) Gigabit Ethernet connector

PIN NO.	Signal
1	TRP1+
2	TRP1-
3	TRP2+
4	TRP3+
5	TRP3-
6	TRP2-
7	TRP4+
8	TRP4-

Connector: RJ-45

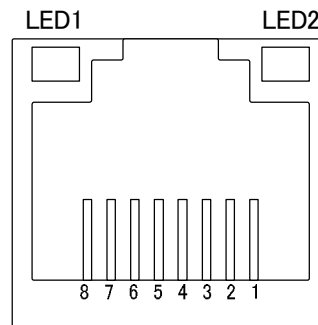

*LED Status

STATUS	LED1	LED2
Power ON	Green Light On	Yellow Light On
1Gb transmission	Green Light On	Yellow Blink On
100Mb transmission	Red Light On	Yellow Blink On

(2) 12-pin connector

PIN NO.	Signal	PIN NO.	Signal
1	GND (+12V)	7	TRIG-A / VD (H)
2	+12V	8	TRIG-B (C)
3	GND	9	TRIG-B (H)
4	AUX	10	FLASH / VD OUT
5	GND	11	N.C.
6	N.C.	12	TRIG-A / VD (C)

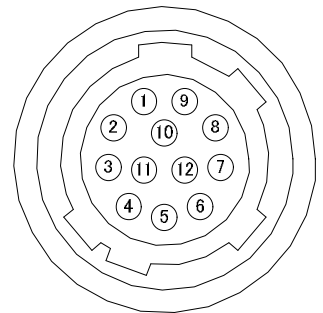

Connector (camera side) : SAMWOO SNH-10-12 (RPCB) or equivalent

Plug (matching cable plug) : Hirose HR10A-10P-12S (01) or equivalent

Please do not unplug and insert cable (camera cable) with a power supplied to a camera.
Install clamp filter (ZCAT 2035-0930A: TDK) at both ends (camera and video processor ends) in the CE marking legion.

Please do not connect 1 pin and 3/5 pin when using PoE. When connecting it, PoE may stop the power supply. Because TRIG-A/VD and TRIG-B are photo coupler input, 8/12 pin is isolated with 1/3/5 pin. When 8/12 pin is connected to GND, please connect to 3 pin or 5 pin.

Note: Please do not input any signal to N.C. pin because machine may break down.

7. Timing chart

7-1. Normal mode

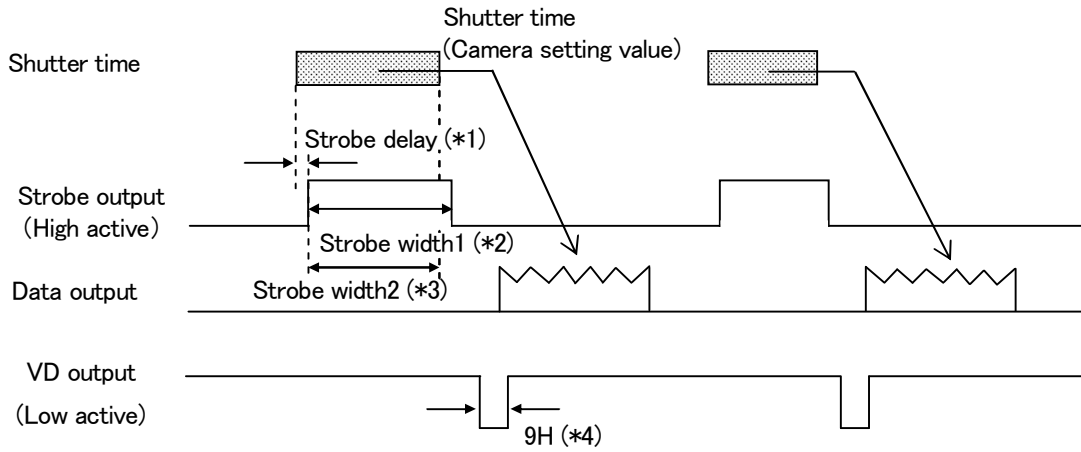

- (*1) 0.32us to 19.57ms Approx.4.78us/step
- (*2) 4.78us to 19.57ms Approx.4.78us/step
- (*3) Shutter Time - Strobe delay (when duration time is set to 0)
- (*4) 1H = Approx. 52.89us

Following graph shows frame rate in each width of picture grabbing when partial scan is ON.

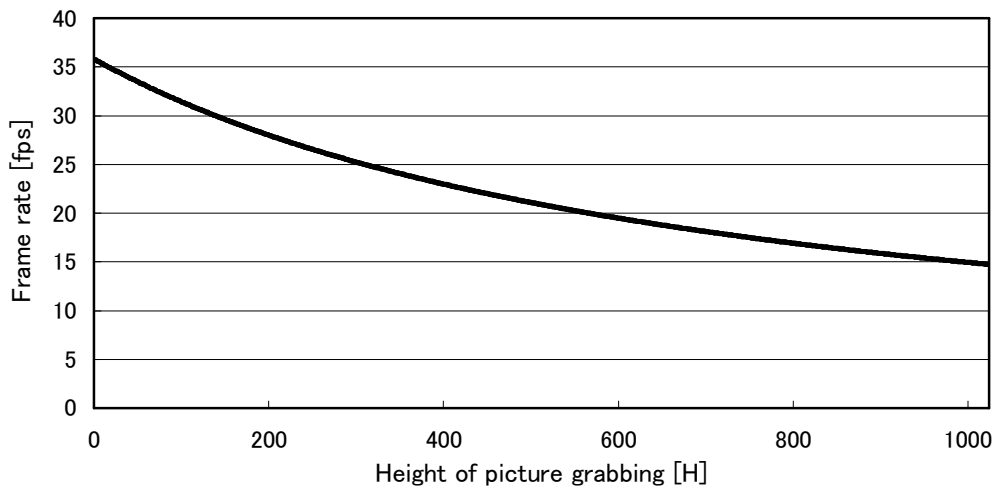

Note: Frame rate can be calculated from following equations using height of picture grabbing.

Total line = 22 + Height + (2061 - Height) / 4 ... omit the figures after the decimal fractions

Frame rate = (37000000 / 1924) / Total line

7-2. Fixed shutter mode

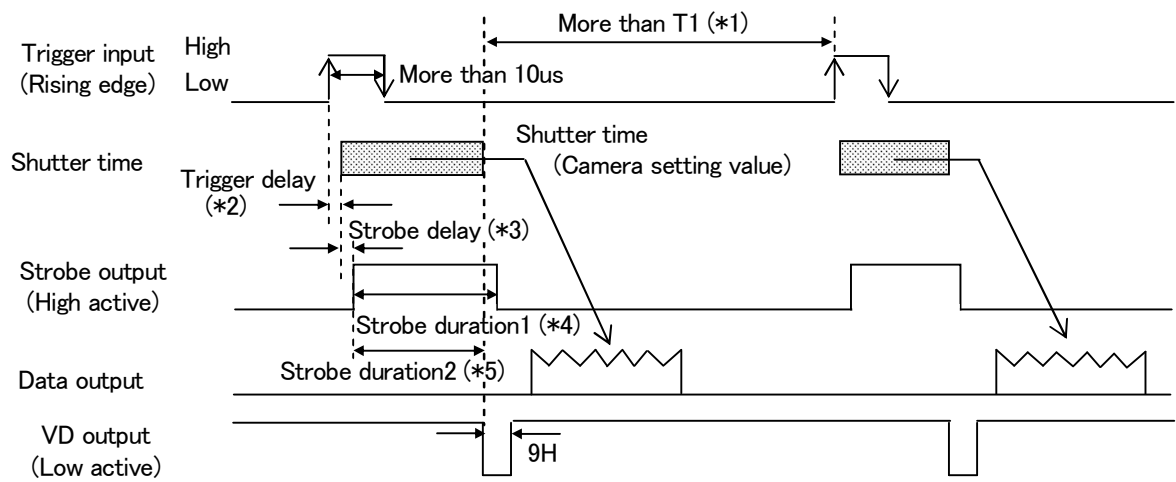

- (*1) $T1 = 1 / \text{Self frame rate [second]}$
- (*2) 3.73us to 19.57ms Approx.4.78us/step
- (*3) 0.24us to 19.57ms Approx.4.78us/step
- (*4) 4.78us to 19.57ms Approx.4.78us/step
- (*5) Shutter Time - Strobe delay (when duration time is set to 0)

7-3. ONE Trigger mode

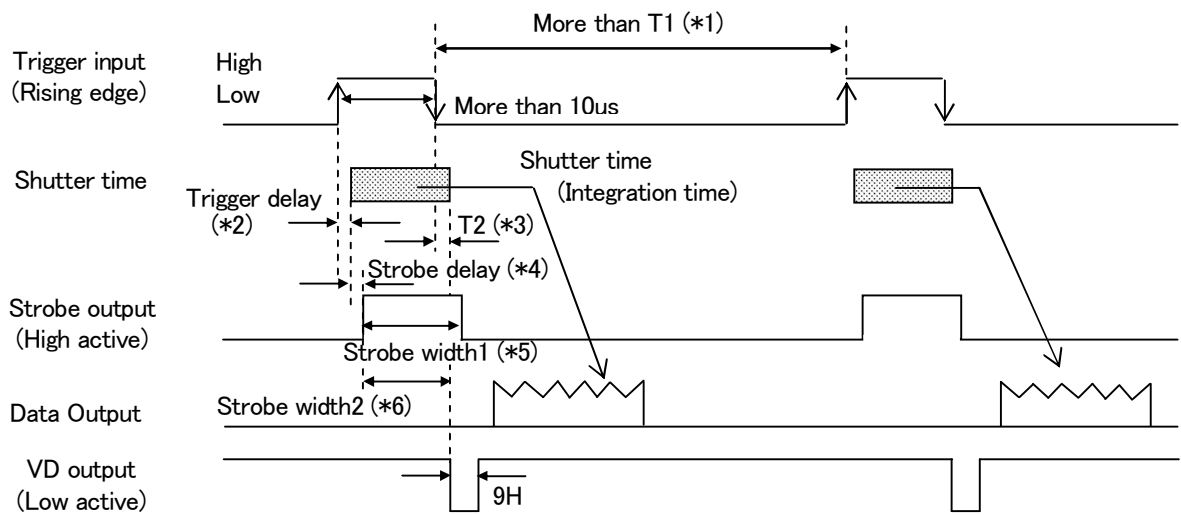

- (*1) $T1 = 1 / \text{Self frame rate [second]}$
- (*2) 3.97us to 19.57ms Approx.4.78us/step
- (*3) $T2 = 56.0us + \text{Trigger delay}$
- (*4) 0.24 to 19.57ms Approx.4.78 μ s/step
- (*5) 4.78 to 19.57ms Approx.4.78 μ s/step
- (*6) Shutter Time - Strobe delay (when duration time is set to 0)

7-4. Reset control mode

(1) When Fixed shutter

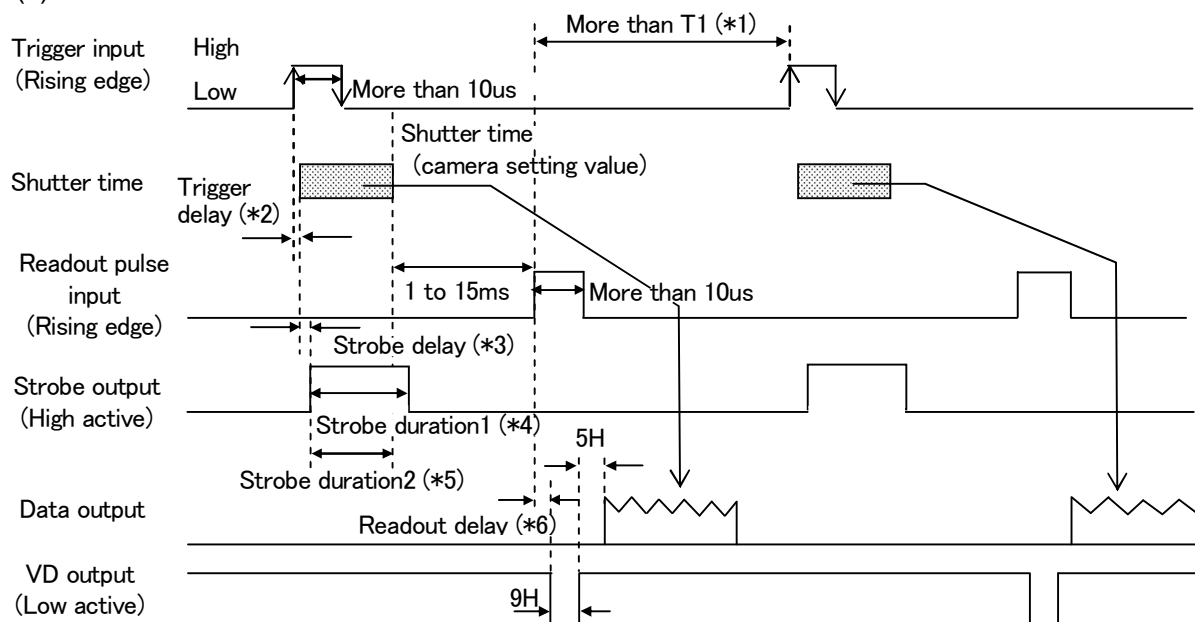

- (*1) $1 / \text{Self frame rate [second]}$
- (*2) 3.73us to 19.57ms Approx.4.78us/step
- (*3) 0.24us to 19.57ms Approx.4.78us/step
- (*4) 4.78us to 19.57ms Approx.4.78us/step
- (*5) Shutter Time - Strobe delay (when duration time is set to 0)
- (*6) 108.70us to 19.68ms Approx.4.78us/step

(2) When ONE Trigger

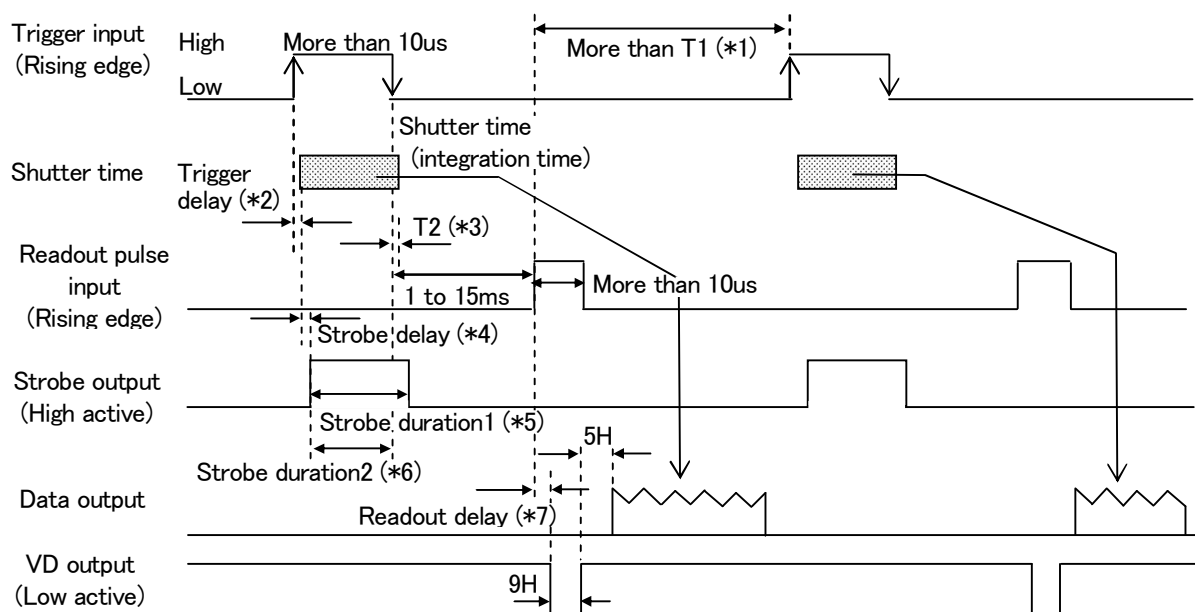

- (*1) $T1 = 1 / \text{Self frame rate [second]}$
- (*2) 3.97us to 19.57ms Approx.4.78us/step
- (*3) $T2 = 56.0\text{us} + \text{Trigger delay}$
- (*4) 0.24us to 19.57ms Approx.4.78us/step
- (*5) 4.78us to 19.57ms Approx.4.78us/step
- (*6) Shutter Time - Strobe delay (when duration time is set to 0)
- (*7) 109.20us to 19.68ms Approx.4.78us/step

Special function of reset control mode

The camera shifts to the output of a normal mode (continuous output) when Trigger input signal passes about 1/3 second in the state of High.

It returns to the Trigger mode if Trigger input signal becomes Low.

However, after becoming Low Trigger input, the period of 50ms becomes a Trigger signal input prohibition period.

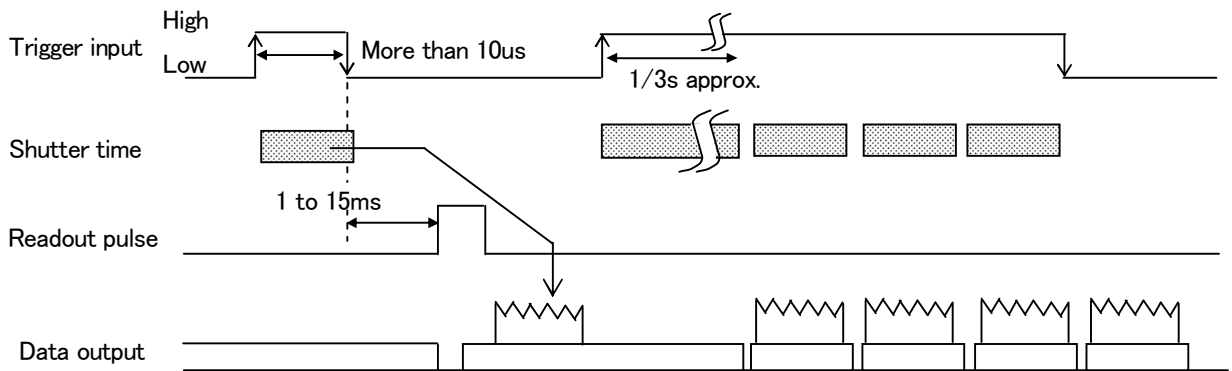

7-5. VD reset mode

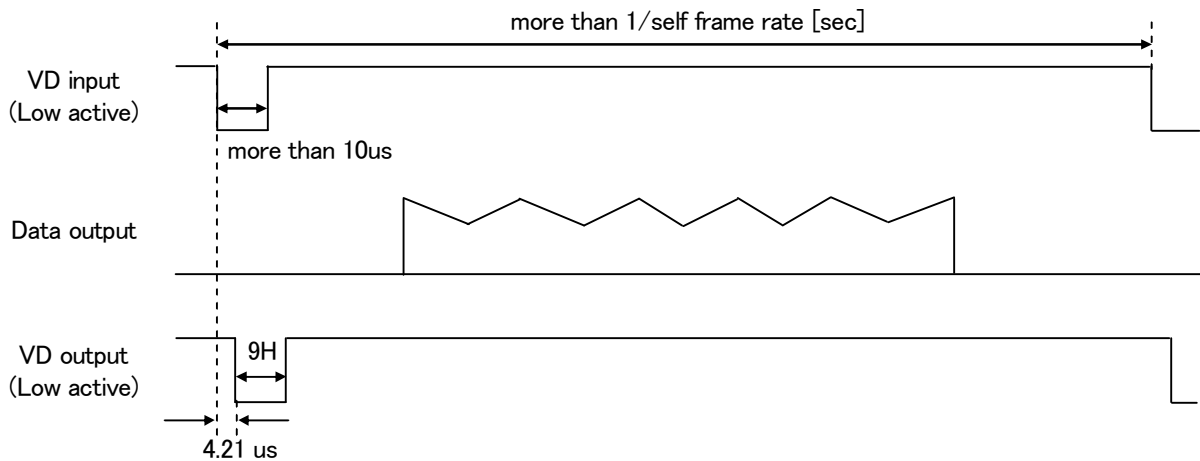

NOTE: If the external VD of cycle which does not match the camera operation mode is input, shutter time has an error.

8. Output sequence when format is RAW

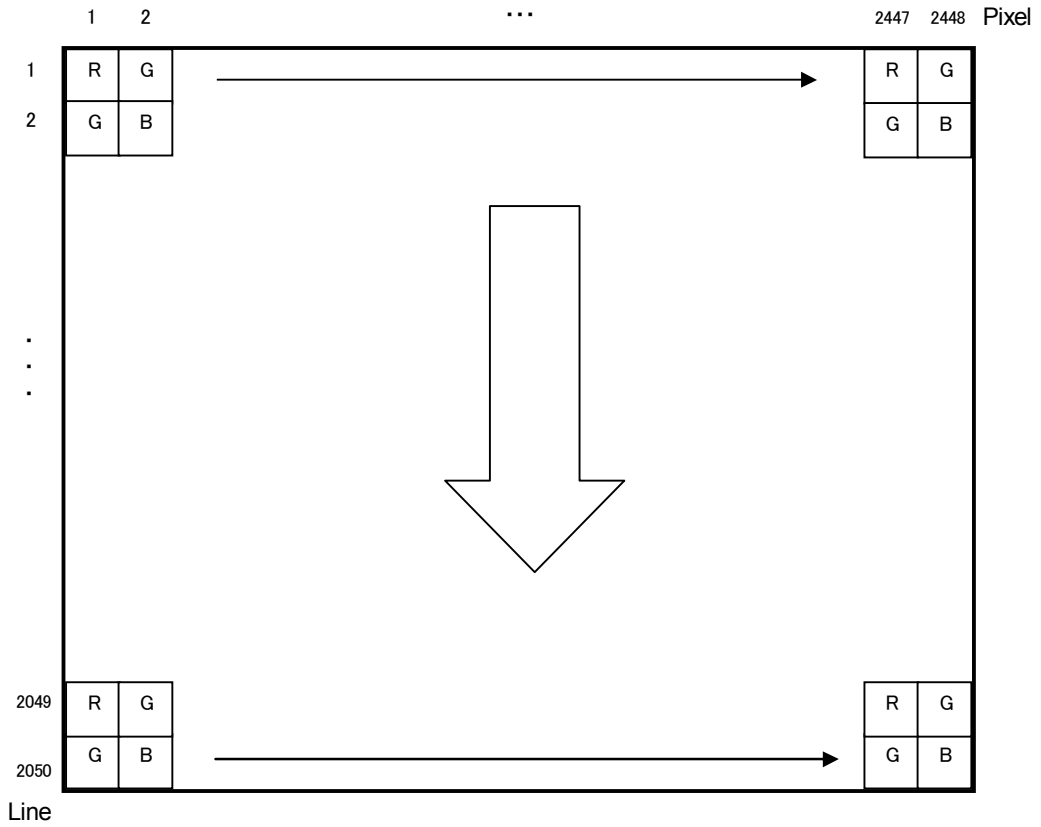

9. Spectral response

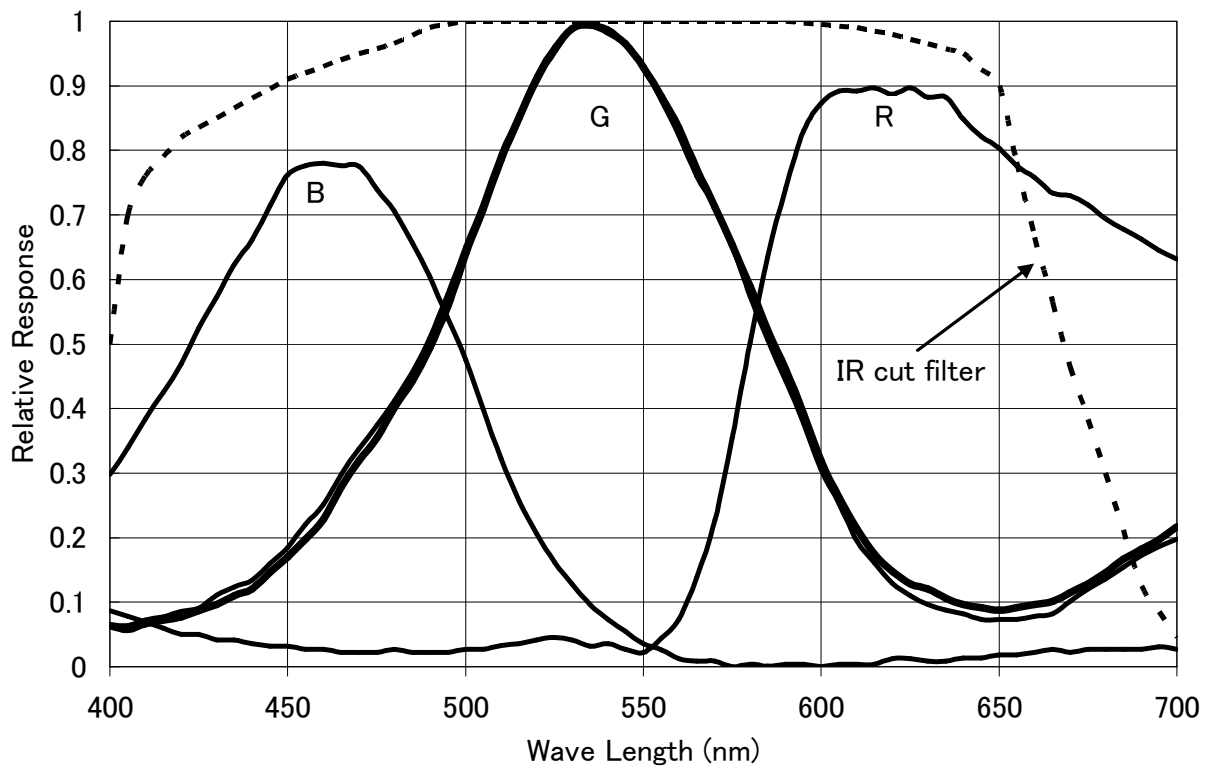

Notice:

These specifications are subject to change without prior notice due to product improvement.

Confirm the most recent specifications at time of order.

Hitachi Kokusai certifies this product complies with the standard warranty conditions of Hitachi Kokusai, and that quality control is implemented to the extent required to comply with these conditions.

RoHS Compliant

This product complies with the requirement of the RoHS(Restriction of the use of Certain Hazardous Substances in Electrical and Electronic Equipment) Directive 2002/95/EC

Warranty and service:

- (1) The guarantee period is one year after the date purchase.
However, the defects due to erroneous use or intentional act are excluded.
- (2) As the defect after expiration of the guarantee period, where product repair is possible, repair will be performed at charge.
- (3) The present Warranty pertains only to the camera unit. Secondary malfunctions attributable to camera failure as well as expenses incurred by disassembly and reassembly of the related system, are beyond the scope of this Warranty.
- (4) Compensation for loss of business, loss or damage to software, database and other contingent losses are beyond the scope of this Warranty.
- (5) Hitachi Kokusai Electric Inc. is not liable for the losses caused when the equipment is used in a system, use for business trades, production process, medical fields, crime prevention applications, etc.
- (6) In the case of camera trouble by miss wiring of cable, it will be considered as out of warranty.