

Progressive Scan CCD Color Camera

KP-FD30M

Specifications

(Revision 1.1)

Hitachi Kokusai Electric Inc.

Jan 12, 2005

1. General

The KP-FD30M is a single CCD type RGB color camera which utilized the progressive scan CCD image sensor with square pixel for VGA format of 1 / 2-inch which adopted the RGB primary color mosaic filter.

The KP-FD30M is equipped with the progressive full frame RGB output of high frame rate(approx. 60 frame/second), the external synchronization(HD/VD), the external trigger function, etc., it is suitable for the image-processing equipment input.

2. Principal features

1) Suitable for the image-processing equipment input.

Small lightweight size, since adoption of multi-connector (picture signals, power supply, serial control signal, etc.) is connectable with one cable, it is the optimal as a microscope and an object for an image-processing equipment input.

2) High resolution and high color fidelity

By adoption of the progressive scan CCD image sensor and RGB primary color mosaic filters, the picture of high vertical resolution and high color fidelity can be acquired.

3) New digital signal processor (DSP)

The clear picture of a high signal to noise ratio (S/N) is obtained by the new digital signal processor (DSP) adoption which has improved luminance signal processing, such as 5H enhancer processing.

4) CCD drive functions

- a) Preset electronic shutter (settable 11 steps from 1/60 second to 1/50,000 second and 27 steps from 1/30 second to 8 second.)
- b) Variable electric shutter (1H steps from 1/60 second to Approx. 1/10,000 second)
- c) Auto electronic shutter[AES] (from 1/60 second to approx. 1/50,000 second)
- d) Frame/field on demand (one trigger and fixed shutter modes)

5) White balance

- a) Auto-tracking white balance (detecting white color in the scene at a color temperature form 2,500K to 6,000K)
- b) Preset white balance [AWC]
- c) Manual white balance. (R, B gain control)

6) Trigger & memory

The still picture continuation output at the time of external trigger mode is possible.

7) External synchronization

As the external synchronization mode of HD/VD inputs system is available, the KP-FD30M is most suitable for system operation. The horizontal sync phase can be adjusting to the on-screen menu and remote control.

8) Picture quality menus

A wide variety of modes and parameters can be selected from menus and adjusted by using rear panel key buttons.

9) Others.....

a) Video signal polarity (Selectable negative/positive)

b) Text display

c) Remote control (Via RS-232C)

3. Specifications

- 1) Imaging device : 1/2-inch progressive scan interline CCD (with on-chip microlenses)
 - Total number of pixels : 692(H) x 504(V)
 - No. of effective pixels : 659(H) x 494(V)
 - Scanning area : 6.52(H) x 4.89(V) mm
 - Unit cell size : 9.9(H) x 9.9(V) μ m (Square pixel)
 - Color filter : R, G, B primary color mosaic filters on chip
- 2) Scanning system : Progressive scan (VGA mode)
- 3) Frequency Horizontal : 31.468 kHz
Vertical : 59.94 Hz
- 4) Sync system : Internal / external (HD/VD auto selection)
 - Internal sync output (D-sub 15pin MULTI connector)
 - HD : 31.468 kHz 2 Vp-p/75 Ω , Negative
 - VD : 59.94 Hz 2 Vp-p/75 Ω Negative
 - SYNC : 2 Vp-p/75 Ω , Negative
 - WE : 5 Vp-p, Negative
 - External sync input (D-sub 15pin MULTI connector)
 - HD : 31.468 kHz 2 to 5 Vp-p, Negative
 - VD : 59.94 Hz 2 to 5 Vp-p, Negative
 - EXT. Trigger input : Low 0 VDC, High 2 to 5 VDC
- 5) Video signal output (D-sub 15pin MULTI connector)
 - RGB output (D-sub 15pin MULTI connector)
 - R : 0.7 Vp-p/75 Ω
 - G : 0.7 Vp-p/75 Ω
 - B : 0.7 Vp-p/75 Ω
 - Sync on G : 0.3 Vp-p Negative
- 6) Video signal processing : Digital processing (input 10 bits)
- 7) S/N (G signal) : More than 50dB (AGC, enhancer and gamma off)
- 8) Resolution (G signal at center)
 - Horizontal : 440 TV lines
 - Vertical : 480 TV lines
- 9) Standard sensitivity : 2,000 lx (F5.6, 100IRE)
- 10) Minimum illumination : 10 lx (F1.4, AGC ON, 50IRE)
- 11) Sensitivity selection : AGC OFF / ON
 - Manual Gain Adjustable at AGC OFF
 - Limit Gain Adjustable at AGC ON

12) Electric shutter speed

- PRESET : Selectable in 11 steps high speed shutter
OFF(1/60), 1/100, 1/250, 1/500, 1/1000, 1/2000, 1/4000
1/10000, 1/20000, 1/30000, 1/50000 second
Selectable in 27 steps low speed shutter
OFF(1/60), 1/30, 1/15, 1/10, 1/7.5, 1/6, 1/5, 1/3.75, 1/3,
1/2.5, 1/2, 1/1.5, 1, 1.5, 2, 2.5, 3, 3.5, 4, 4.5, 5, 5.5, 6, 6.5,
7, 7.5, 8 second
- AES : From 1/60 second to approx. 1/50,000 second
(Response : SLOW, NORMAL, FAST)
- VARIABLE : Approx. 1H steps from 1/60 second to 1/10,000 second

13) Ext. Trigger

- :
a) One trigger mode
b) Fixed shutter mode
NORMAL(1/60), 1/250, 1/500, 1/1000, 1/2000, 1/4000
1/10000, 1/50000 second
Memory mode: OFF/ON

14) Auto level control[ALC]

- (The auto level control system of AES, lens iris and AGC.)
: AVERAGE / PEAK&AVERAGE / AREA
(Scanning area is selectable from 9 area.)

15) Auto-iris lens outputs

- Iris control voltage input (galvanometer) type lens
: Coupling coil impedance
Damper : $1,150\Omega \pm 10\%$
Drive : $190\Omega \pm 10\%$

16) White balance

- : Selectable in 3 modes
Auto-tracking[ATW] / preset[AWC] /
R/B gain manual control[MANUAL] /

17) Text display

- : 24 alpha-numeric characters in one line

18) Picture adjustment

- : Modes and settings can be selected and adjusted from
on-screen menu

19) Remote control

- : Modes and settings can be selected and adjusted
from PC.
RS-232C level, Connector: D-sub 15pin MULTI connector

- 20) Power supply : 12 VDC \pm 10 %
- 21) Power consumption : Approx. 370 mA
(Including 60mA for auto-iris lens)
- 22) Lens mount : C/CS mount (Flange-back adjustment)
- 23) Ambient temperature
 Operating : -10 to +50 °C, 30 to 80 %RH
 Storage : -20 to +60 °C, 20 to 90 %RH
- Note : If operated continuously, be sure to use at less than +40 °C(104F)
 for long term stable performance.
- 24) Vibration endurance : 68.65 m/s² (10 to 200Hz, 30 minutes each on XYZ axes)
 Note : Do not subject to strong vibration for long periods of time.
- 25) Shock endurance : 490.3 m/s² (vertical, horizontal, once each face)
- 26) External dimensions : 58(W) x 58(H) x 48(D)
(not including lens and protrusions)
- 27) Mass : Approx. 220g (without lens)
- 28) Supplied equipment : Camera 1
 Operating instructions 1
- 29) Optional accessories : DC input plug (R03-P3F)
 Lens plug (E4-191J-100)
 MULTI cable plug Housing (KEC-15P)
 Pin contact (JK-SP2140)
 Cover (JK-C151C)
 Screw (No4-40UNC)

30) MULTI pin arrangement (D-sub 15pin)

Pin no.	Symbol	Signal name
1	R	R output
2	G	G output
3	B	B output
4	WE	WE out
5	GND	Ground
6	GND(V)	Video ground
7	GND(V)	Video ground
8	GND(V)	Video ground
9	12V	+12V input
10	TRG	Trigger input
11	GND	Ground
12	RXD	Serial data input (RS-232C level)
13	HD	HD input / HD output / SYNC out
14	VD	VD input / VD output
15	TXD	Serial data output (RS-232C level)

31) Timing chart

a) Video signal timing

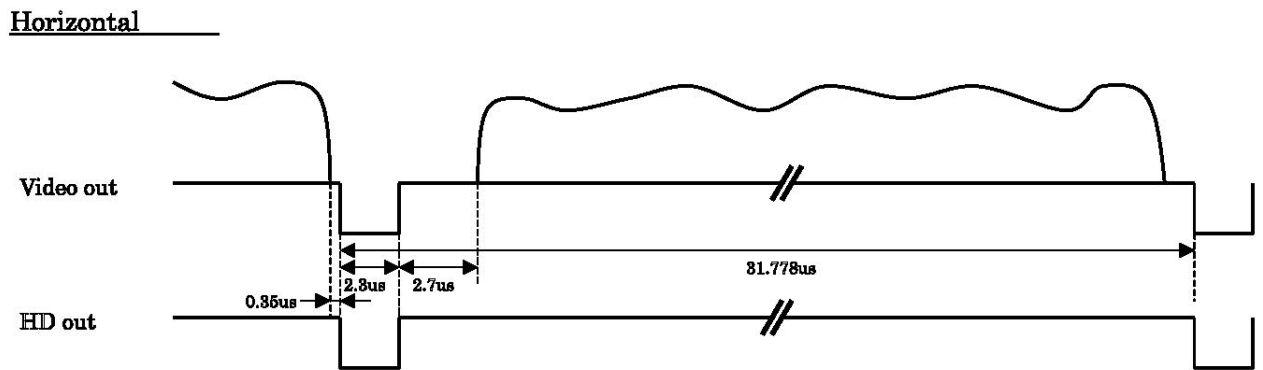
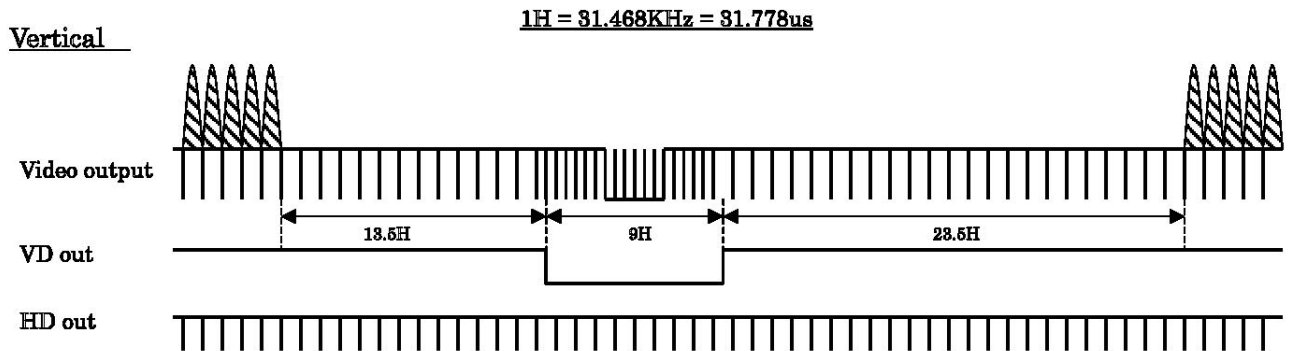

b) HD/VD External timing

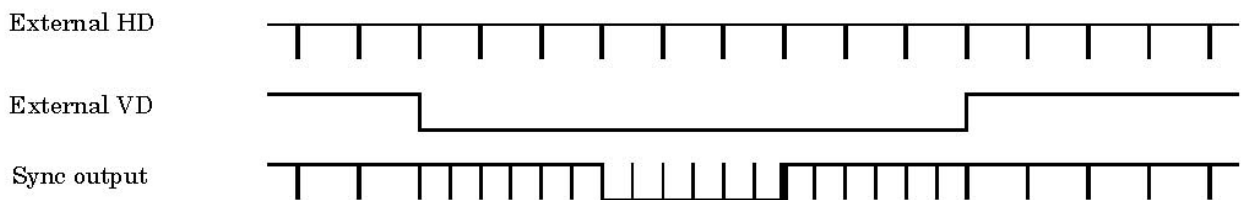

c) External trigger (One trigger mode)

* Memory Mode: OFF

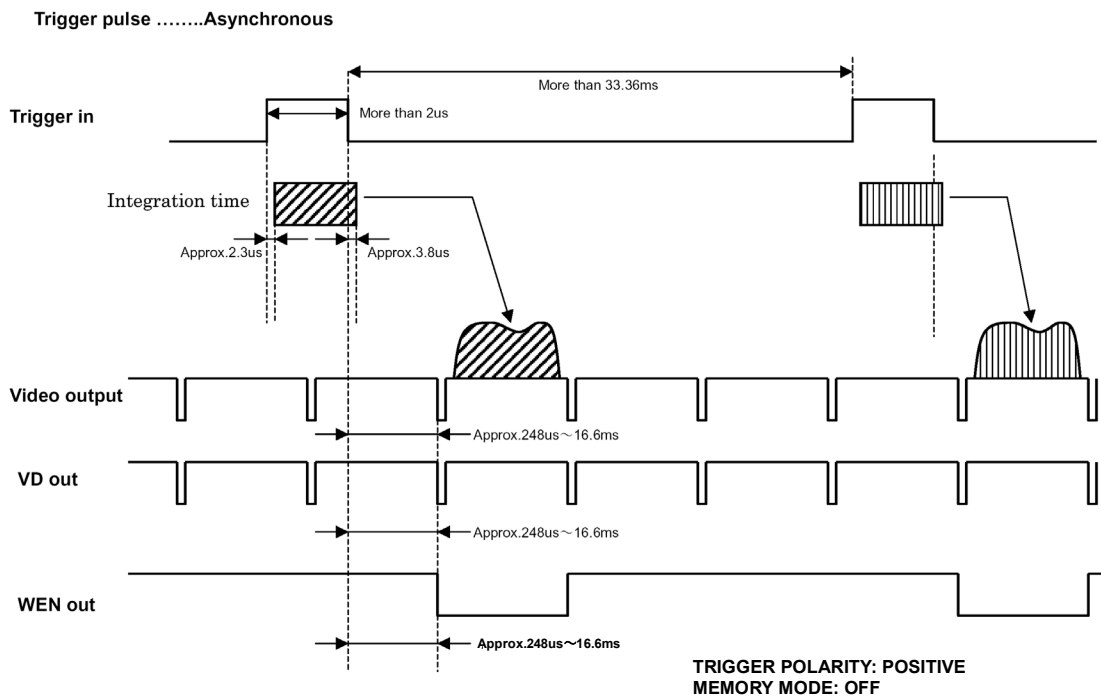

* Memory Mode: ON

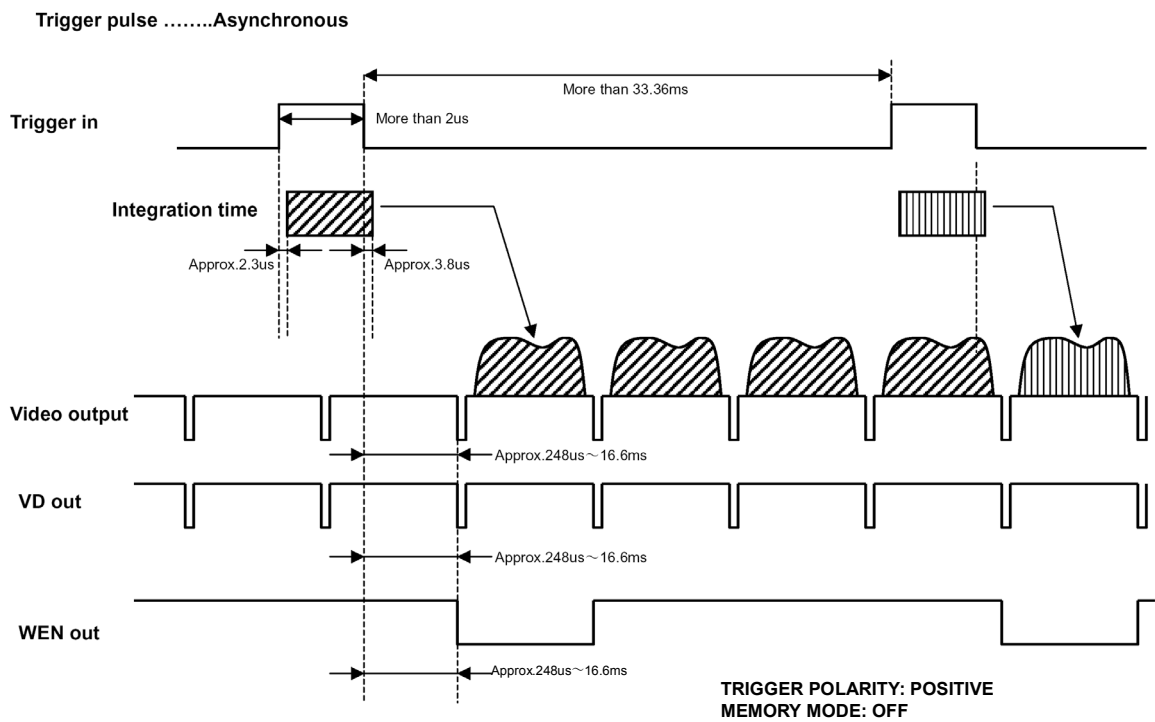

d) External trigger (Fixed shutter mode)

* Memory Mode: OFF

Trigger pulse Latch in internal HD

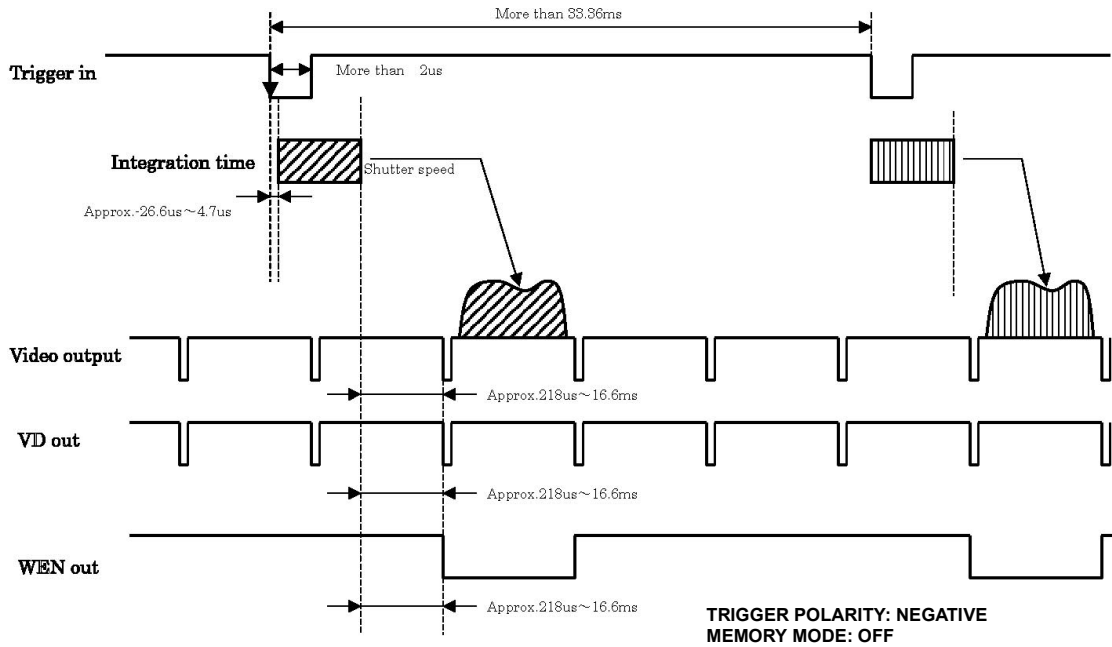

* Memory Mode: ON

Trigger pulse Latch in internal HD

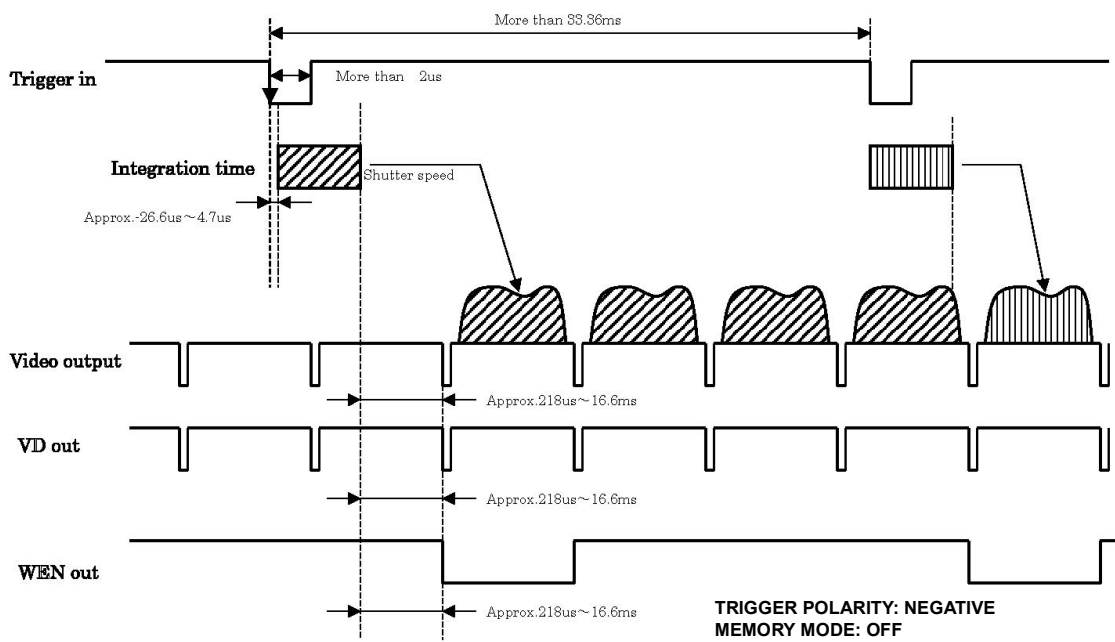

32) External view

KP-FD30M

- MASS : APPROX. 220 g
- COLOR : BLACK
- UNIT : mm
- SCALE : NTS

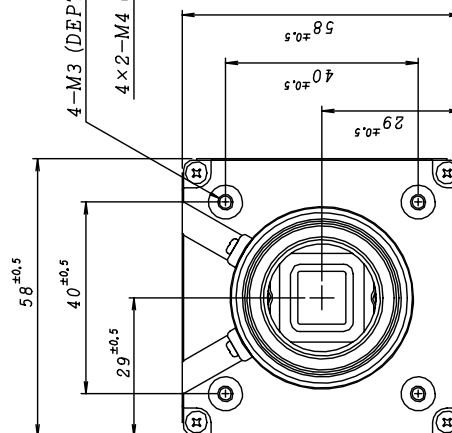
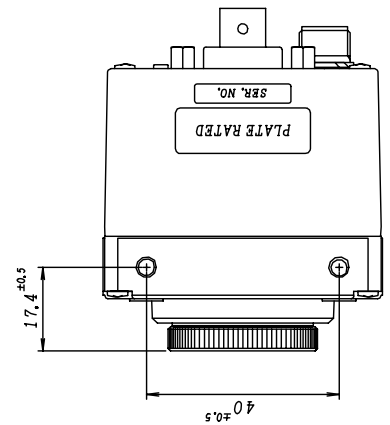
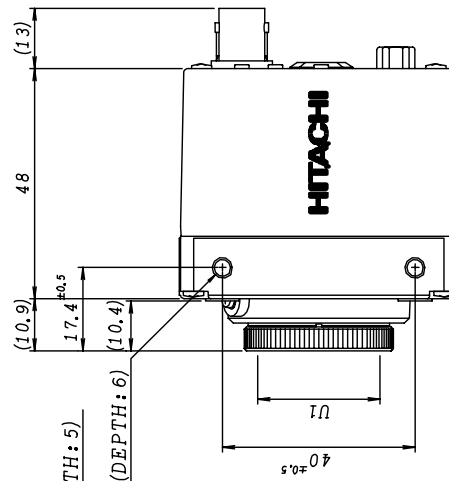
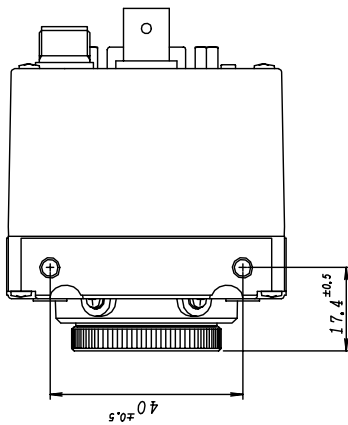
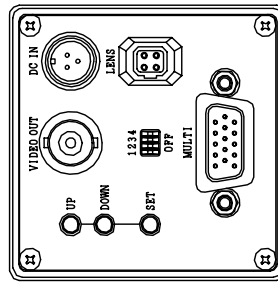

Notice:

These specifications are subject to change without prior notice due to product improvement. Confirm the most recent specifications at time of order.

Hitachi Kokusai Electric certifies this product complies with the standard warranty conditions of Hitachi Kokusai Electric, and that quality control is implemented to the extent required to comply with these conditions.

Warranty and service:

- 1) The guarantee period is one year after the data purchase. However, the defects due to erroneous use or intentional act are excluded.
- 2) As the defect after expiration of the guarantee period, where product repair is possible, repair will be performed at charge.
- 3) The present Warranty pertains only to the camera unit. Secondary malfunctions attributable to camera failure as well as expenses incurred by disassembly and reassembly of the related system, are beyond the scope of this Warranty.
- 4) Compensation for loss of business, loss or damage to software, database and other contingent losses are beyond the scope of this Warranty.
- 5) Hitachi Kokusai Electric Inc. is not liable for the losses caused when the equipment is used in a system, use for business trades, production process, medical fields, crime prevention applications, etc.
- 6) The parts used in the equipment have their respective lives. The lives of such parts will be shortened under the environments of high temperature or high humidity. When the stable operation is required for a long time, it is recommended to perform periodical maintenance and inspection every year or every two years.

Correction and change career

Sep 10, 2004 Revision 1.0 is issued.

Jan 12, 2005 Revision 1.1 is issued.

Reasons: Page 4, 3 1) The error in writing is corrected.

Scanning area ~~7.48(H)x6.15(V)mm~~→6.52(H)x4.89(V)mm