

# Gigabit Ethernet

## Progressive Scan CCD Camera

### KP-F500GV

## Specifications Ver.1.00

### 1. General

The KP-F500GV is single CCD type camera which utilized the progressive scan CCD image sensor with square pixel for VGA format of 2/3-inch.

By adoption of Gigabit Ethernet interface, high-speed connection of maximum of 1 Gbps can be possible.

Moreover, by using hub or switcher, construction of multiple camera system can be easily performed.

### 2. Outstanding features

#### (1) High resolution

The 2/3-inch 5,050,000 pixels square lattice progressive scan CCD achieve a high resolution of 2456(H) x 2058(V).

#### (2) Gigabit Ethernet interface

High-speed serial interface Gigabit Ethernet is supported and direct connection is possible to PC by the diameter cable of thin as compared with parallel output. It is possible to 100m.

#### (3) GigE Vision (Ver 1.00) correspondence

Based on Industrial camera interface standard GigE Vision, a maximum of 1Gbps high speed data transmit is available and suitable for image processing.

#### (4) GENiCAM (Ver. 1.00) correspondence

Development of camera control system is easy because industrial camera control API "GENiCAM" lead EMVA (European Machine Vision Association).

#### (5) PoE correspondence

Power supply can be input via Ethernet cable (Power over Ethernet).

#### (6) Remote control

- Multi-step electronic shutter (from 1/16 to 1/50000 second in 8 steps)
- Variable shutter (from 10 to 1/100000 second)
- The image capture at desired timing using the external trigger signal and other various functions are set by remote control via a Gigabit Ethernet cable.

GigE Vision™ and the distinctive logo are trademarks of AIA (Automated Imaging Association).

GENiCAM™ is a trademark of EMVA (European Machine Vision Association).

Ethernet is a trademark of XEROX Corporation.

# Hitachi Kokusai Electric

### 3. Specifications

(1) Imaging device	2/3-inch progressive scan interline CCD
Total pixels	2536 (H) x 2068 (V)
Effective pixels	2456 (H) x 2058 (V)
Pixel size	3.45 um (H) x 3.45 um (V) (square lattice)
(2) Scanning area	8.47 mm (H) x 7.10 mm (V)
(3) Scanning system	Progressive
(4) Aspect ratio	5 : 4
(5) Frame rate	16 frames per second (full pixel readout)
(6) Sync system	Internal / external
(7) Lens mount	C mount
(8) Flange focal distance	17.526 mm
(9) Video output	
Interface	Gigabit Ethernet
Protocol	GigE Vision compliant
Transfer	1 Gbit per second
Image format	Mono 8/10/12bit
Maximum image size	2448 (H) x 2050 (V)
Frame rate	16 frame per second
	*Frame rate is different for following format
	Mono 10/12bit: 11 frame per second
(10) Sensitivity	400lx, F8, 3200K
(11) Minimum illumination	1.0 lx (F1.4 GAIN MAX)
(12) Electric shutter	OFF / Auto (AES) / Manual (PRESET or VARIABLE)
	OFF is normal exposure (frame rate)
PRESET	1/16, 1/60, 1/100, 1/250, 1/1000, 1/2000, 1/10000, 1/50000 second.
VARIABLE	10 to 1/100000 second
(13) External trigger shutter	
Mode	Fixed shutter
	One trigger
	VD Sync
	Reset control
Input	Via Gigabit Ethernet cable (Software trigger)
	12-pin connector (Hardware trigger)
Input level	24Vp-p +/- 1V
Threshold	3.7V +/- 0.5V (Low --> High)
	3.5V +/- 0.5V (High --> Low)
Input polarity	High / Low adjustable
Input delay	Adjustable

(14) External sync signal	
VD output	5Vp-p +/- 0.3V
Strobe out	5Vp-p +/- 0.3V
Output Polarity	High / Low adjustable
Strobe delay	Adjustable
Strobe duration	Adjustable
(15) Partial scan	Grabbing image area is adjustable at horizontal / vertical
(16) ALC (Auto level control)	Adjustable for video level
(17) Gain	Auto / Manual (0dB to 12db)
(18) Gamma	OFF ( $\gamma = 1$ ) / ON
(19) V-Binning	OFF / ON
(20) Sharpness	Adjustable
(21) Black level	Adjustable
(22) Knee	Adjustable (Knee point and Knee slope)
(23) Power supply voltage	DC+12V +/- 1V (input from 12-pin connector) 48V (PoE)
(24) Current consumption	Approx. 7.8W (DC+12V) When partial scan is on, Max Approx. 8.4W (DC+12V)
(25) Ambient	
Performance	0 to +40°C (+32 to +104 F), less than 90 % RH
Operation	-10 to +50°C (+14 to +122 F), less than 90 % RH
Storage	-20 to +60°C (-4 to +140 F), less than 70 % RH (without dew condensation)
	Note : If operated continuously, be sure to use at less than +40°C (+104F) for long term stable performance.
(26) Vibration endurance	98.6 m/s <sup>2</sup> or less (10 to 200 to 15Hz, 30 minutes each on XYZ axes) (Do not subject to strong vibration for long periods of time.)
(27) Shock endurance	490.3 m/s <sup>2</sup> or less (vertical, horizontal, once each face)
(28) External dimensions	44(W) x 29(H) x 72(D) mm (not including lens and protrusions)
(29) Mass	Approx. 140g

#### 4. Composition

- (1) Camera (with Dummy glass)
- (2) CD-ROM (Operation manual, Control software and SDK)
- (3) Composition table

#### 5. Optional accessories

- (1) Dummy glass (AR coated)                      ARC1214
- (2) IR cut filter                                      IRC650
- (3) Junction box                                      JU-F30,
- (4) Tripod adaptor                                  TA-M1
- (5) 12pin plug                                      HR10A-10P-12S(01)
- (6) Camera cable

	Molded type	Shield type
2 m	C-201KSM	C-201KSS
5 m	C-501KSM	C-501KSS
10 m	C-102KSM	C-102KSS

In the CE Marking region, use the shield type and install clamp filter (ZCAT2035-0930A: TDK) at both ends of the cable.

- (7) LAN cable (Commercial item)              CAT5E Straight cable  
    CAT5E Cross cable  
    CAT6 Straight cable  
    CAT6 Cross cable

## 6. Specification of Digital output connector

### (1) Gigabit Ethernet connector

PIN NO.	Signal
1	TRP1+
2	TRP1-
3	TRP2+
4	TRP3+
5	TRP3-
6	TRP2-
7	TRP4+
8	TRP4-

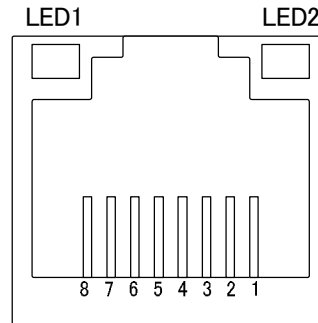

Connector: RJ-45

\*LED Status

STATUS	LED1	LED2
Power ON	Green Light On	Yellow Light On
1Gb transmission	Green Light On	Yellow Blink On
100Mb transmission	Red Light On	Yellow Blink On

### (2) 12-pin connector

PIN NO.	Signal	PIN NO.	Signal
1	GND (+12V)	7	TRIG-A / VD (H)
2	+12V	8	TRIG-B (C)
3	GND	9	TRIG-B (H)
4	AUX	10	FLASH / VD OUT
5	GND	11	N.C.
6	N.C.	12	TRIG-A / VD (C)

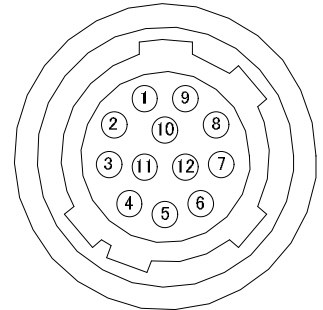

Connector (camera side) : SAMWOO SNH-10-12 (RPCB) or equivalent

Plug (matching cable plug) : Hirose HR10A-10P-12S (01) or equivalent

Please do not unplug and insert cable (camera cable) with a power supplied to a camera.  
Install clamp filter (ZCAT 2035-0930A: TDK) at both ends (camera and video processor ends) in the CE marking legion.

Please do not connect 1 pin and 3/5 pin when using PoE. When connecting it, PoE may stop the power supply. Because TRIG-A/VD and TRIG-B are photo coupler input, 8/12 pin is isolated with 1/3/5 pin. When 8/12 pin is connected to GND, please connect to 3 pin or 5 pin.

Note: Please do not input any signal to N.C. pin because machine may break down.

## 7. Timing chart

### 7-1. Normal mode

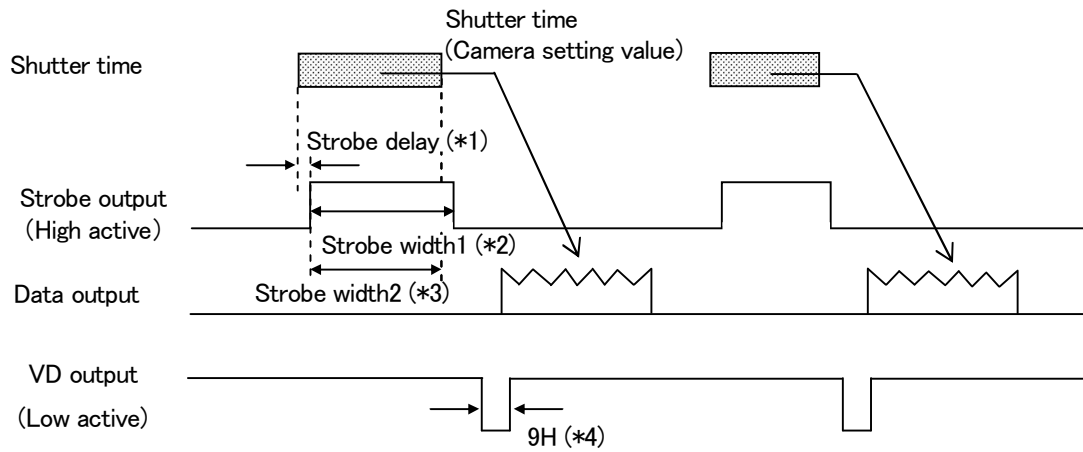

- (\*1) 0.19us to 11.2ms Approx.2.70us/step
- (\*2) 2.70us to 11.2ms Approx.2.70us/step
- (\*3) Shutter Time - Strobe delay (when duration time is set to 0)
- (\*4) 1H = 1H = Approx. 30.46us

Following graph shows frame rate in each width of picture grabbing when partial scan is ON.

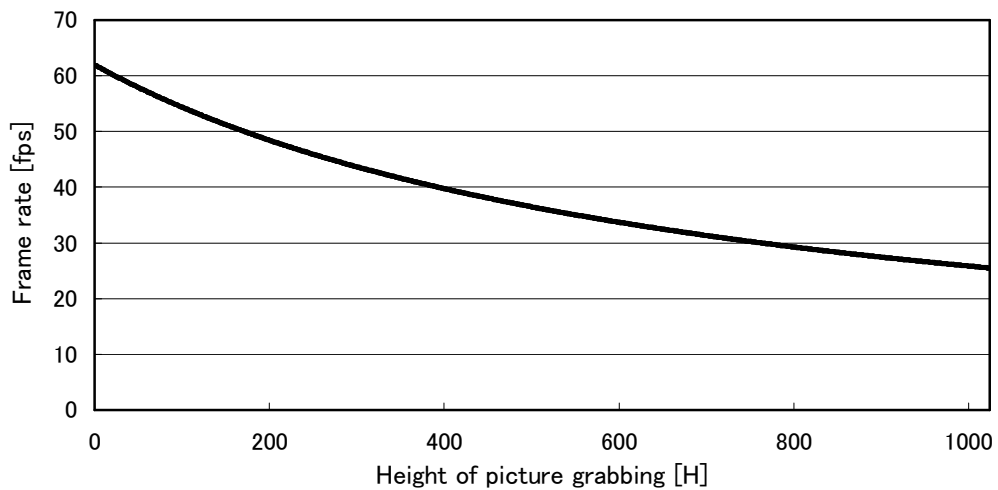

Note: Frame rate can be calculated from following equations using width of picture grabbing.

Total line = 22 + Width + (2061 - Height) / 4 ... omit the figures after the decimal fractions

Frame rate = (64000000 / 1924) / Total line

### 7-2. Fixed shutter mode

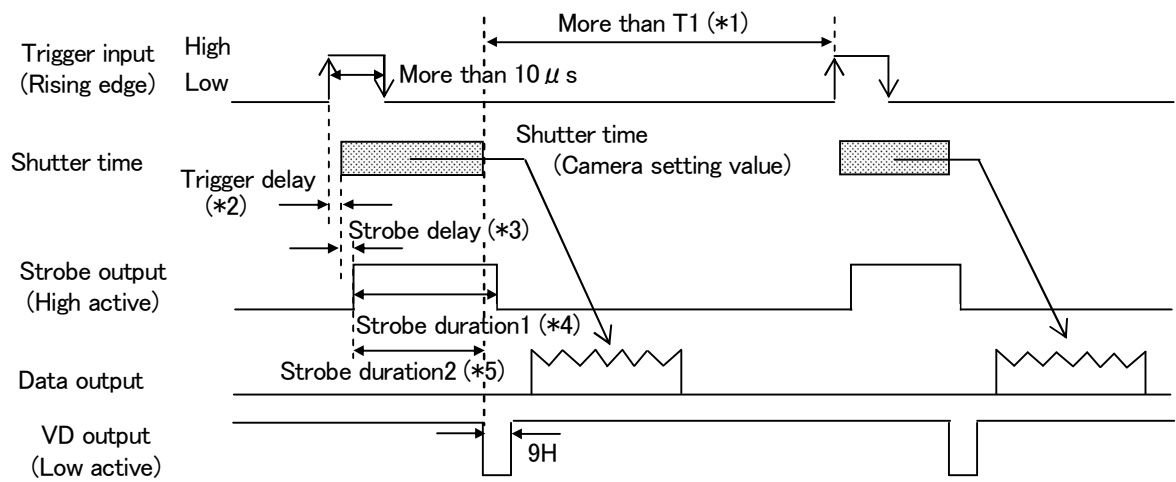

- (\*1)  $T1 = 1 / \text{Self frame rate [second]}$
- (\*2) 4.42μs to 11.2ms Approx.2.70μs/step
- (\*3) 0.14μs to 11.2ms Approx.2.70μs/step
- (\*4) 2.70μs to 11.2ms Approx.2.70μs/step
- (\*5) Shutter Time - Strobe delay (when duration time is set to 0)

### 7-3. ONE Trigger mode

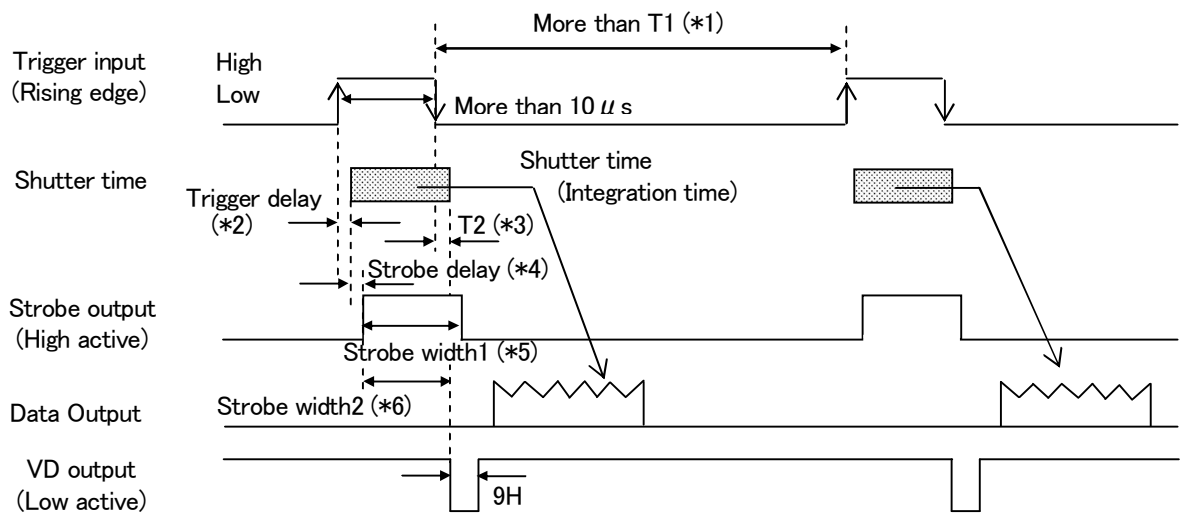

- (\*1)  $T1 = 1 / \text{Self frame rate [second]}$
- (\*2) 4.23μs to 11.2ms Approx.2.70μs/step
- (\*3)  $T2 = 30.6\mu\text{s} + \text{Trigger delay}$
- (\*4) 0.14 to 11.2ms Approx.2.70 μs/step
- (\*5) 2.70 to 11.2ms Approx.2.70 μs/step
- (\*6) Shutter Time - Strobe delay (when duration time is set to 0)

## 7-4. Reset control mode

### (1) When Fixed shutter

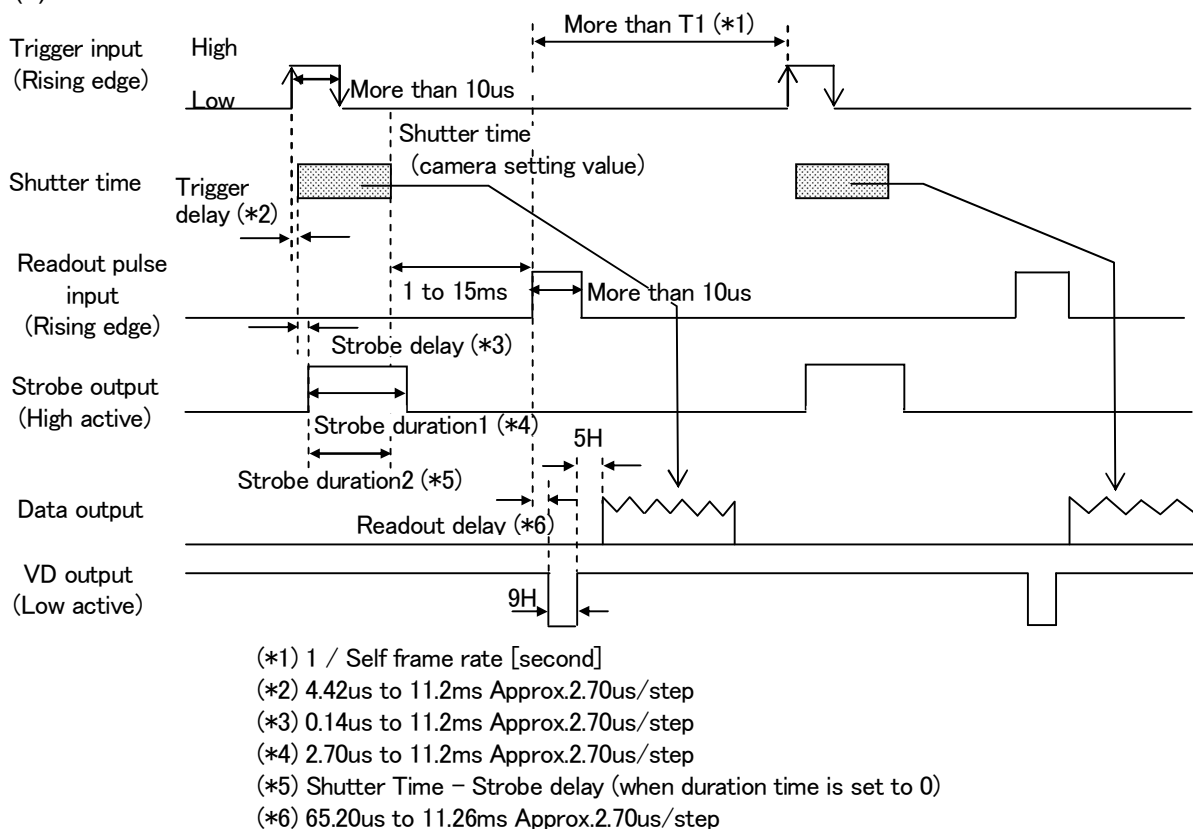

### (2) When ONE Trigger

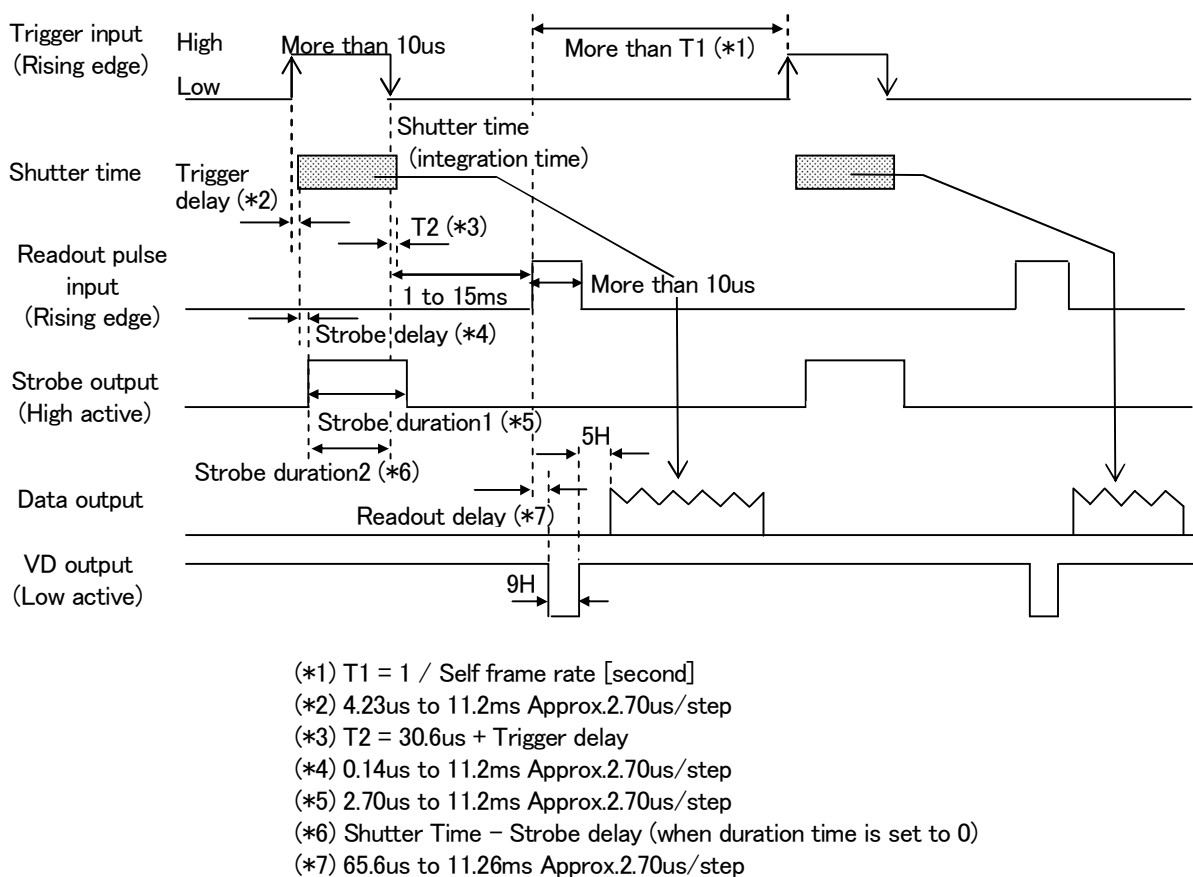

### Special function of reset control mode

The camera shifts to the output of a normal mode (continuous output) when Trigger input signal passes about 1/3 second in the state of High.

It returns to the Trigger mode if Trigger input signal becomes Low.

However, after becoming Low Trigger input, the period of 50ms becomes a Trigger signal input prohibition period.

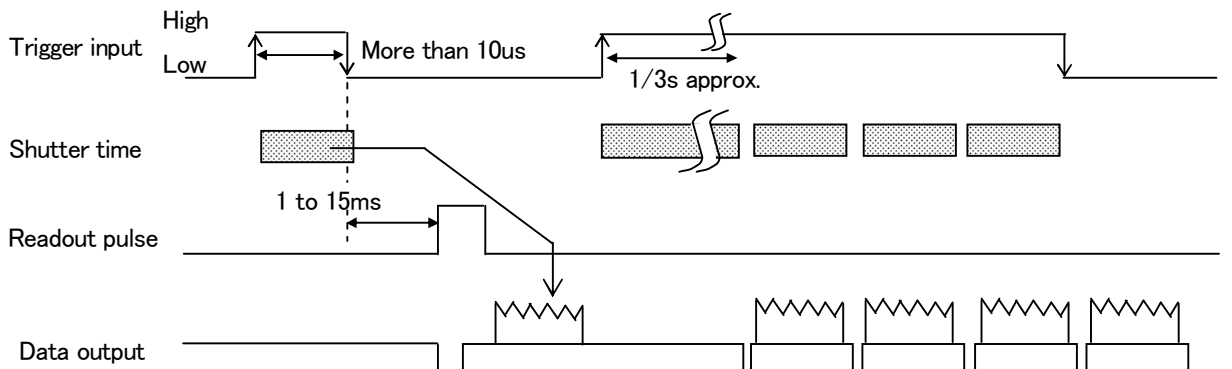

### 7-5. VD reset mode

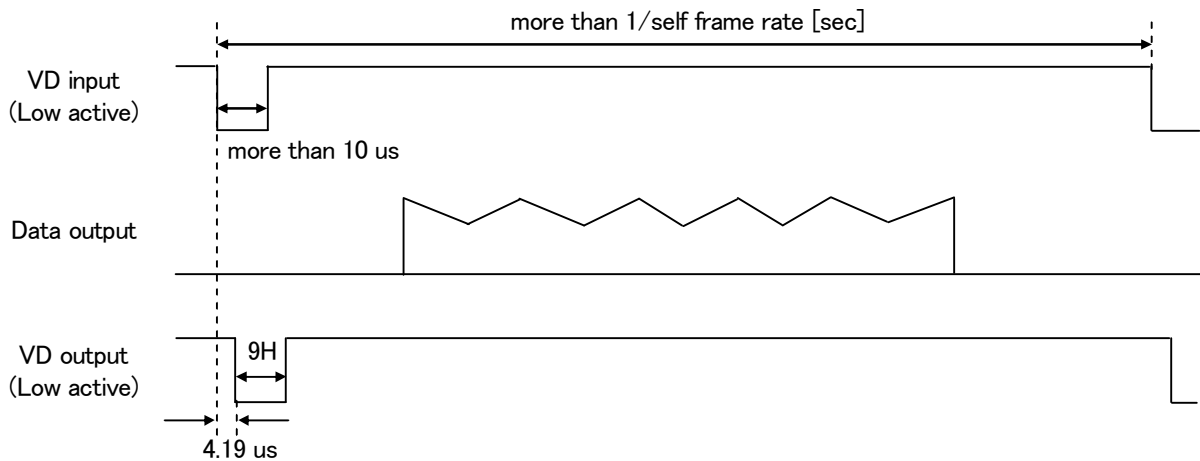

NOTE: If the external VD of cycle which does not match the camera operation mode is input, shutter time has an error.

9. Spectral response

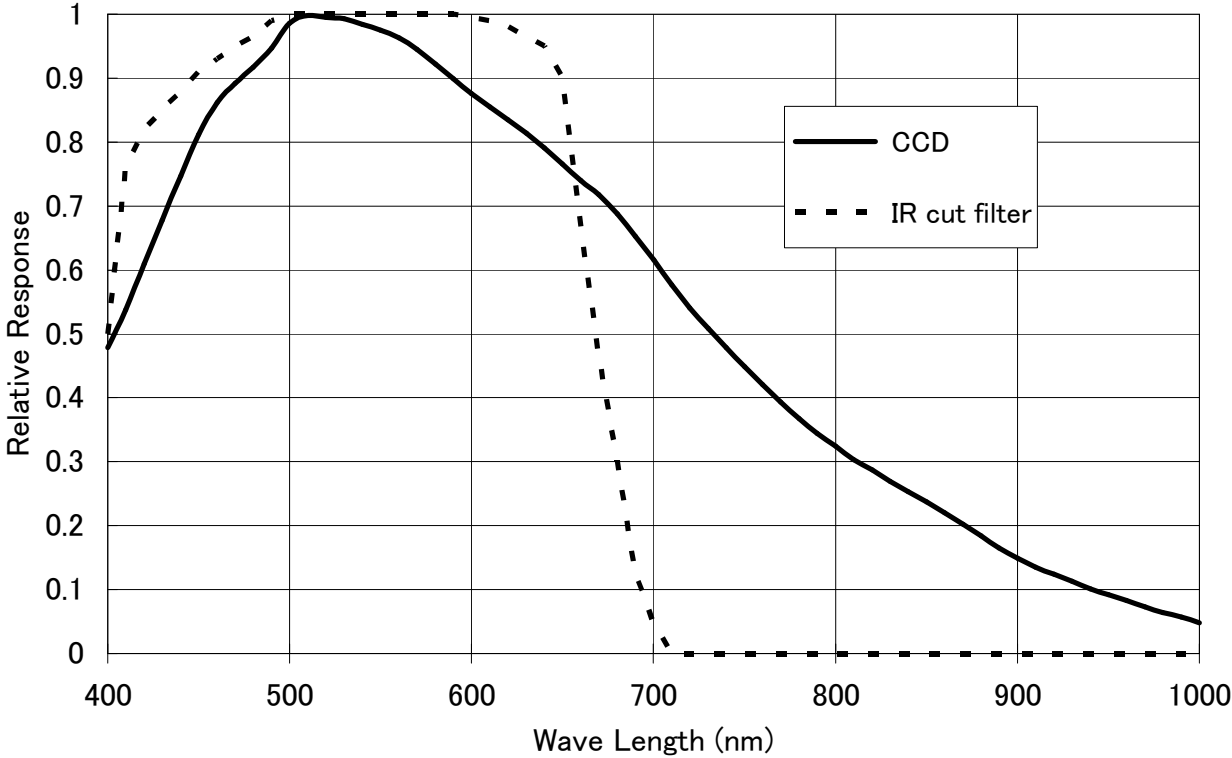

10. External view

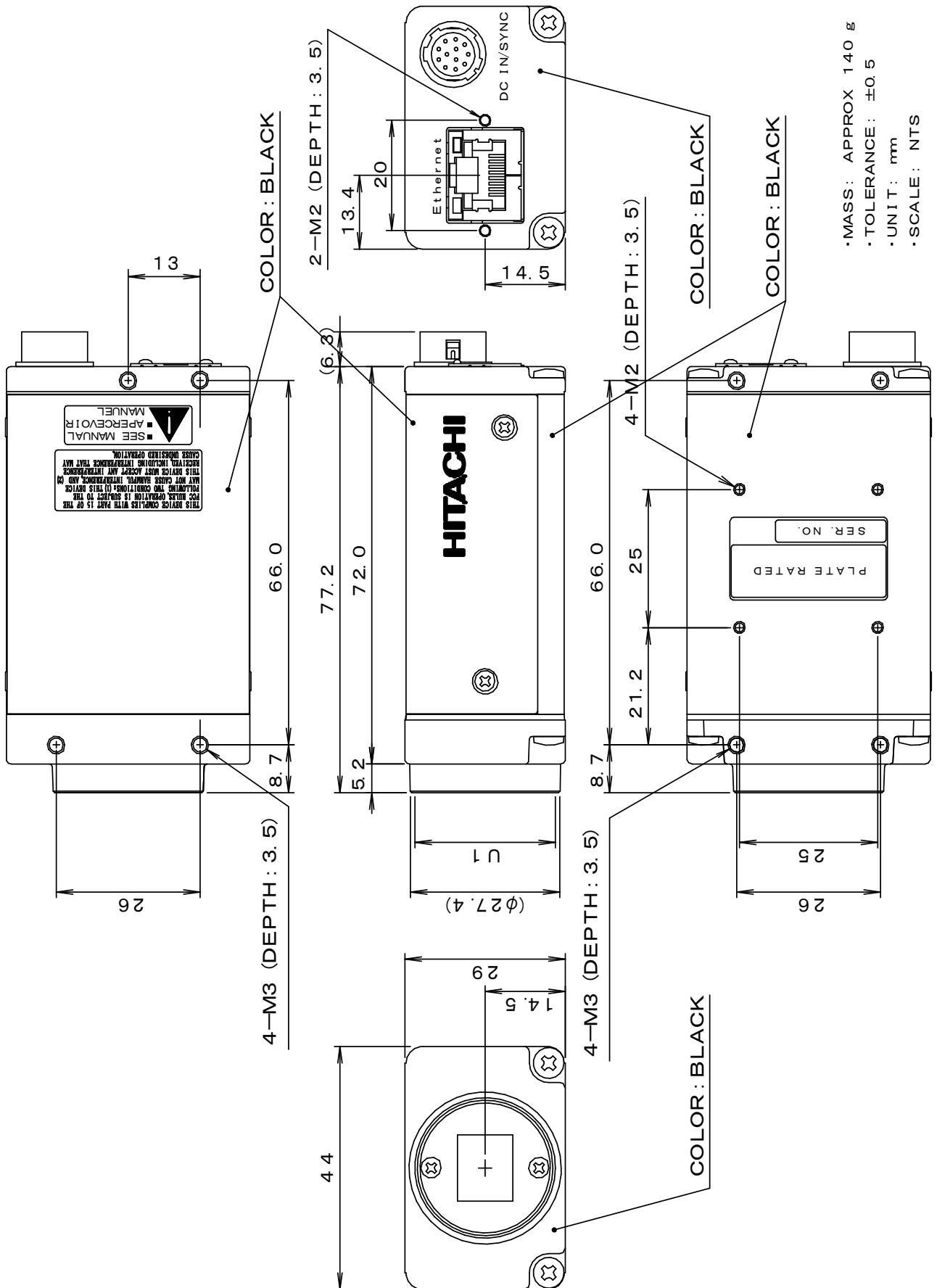

- MASS: APPROX 140 g
- TOLERANCE: ±0.5
- UNIT: mm
- SCALE: NTS

**Notice:**

These specifications are subject to change without prior notice due to product improvement.

Confirm the most recent specifications at time of order.

Hitachi Kokusai certifies this product complies with the standard warranty conditions of Hitachi Kokusai, and that quality control is implemented to the extent required to comply with these conditions.

**RoHS Compliant**

This product complies with the requirement of the RoHS(Restriction of the use of Certain Hazardous Substances in Electrical and Electronic Equipment) Directive 2002/95/EC

**Warranty and service:**

- (1) The guarantee period is one year after the data purchase.  
However, the defects due to erroneous use or intentional act are excluded.
- (2) As the defect after expiration of the guarantee period, where product repair is possible, repair will be performed at charge.
- (3) The present Warranty pertains only to the camera unit. Secondary malfunctions attributable to camera failure as well as expenses incurred by disassembly and reassembly of the related system, are beyond the scope of this Warranty.
- (4) Compensation for loss of business, loss or damage to software, database and other contingent losses are beyond the scope of this Warranty.
- (5) Hitachi Kokusai Electric Inc. is not liable for the losses caused when the equipment is used in a system, use for business trades, production process, medical fields, crime prevention applications, etc.
- (6) In the case of camera trouble by miss wiring of cable, it will be considered as out of warranty.