

Gigabit Ethernet Progressive Scan CCD Camera KP-F33GV Specifications Ver.1.01

1. General

The KP-F33GV is single CCD type camera which utilized the progressive scan CCD image sensor with square pixel for VGA format of 1/3-inch.

By adoption of a Gigabit Ethernet interface, high-speed connection of maximum of 1Gbps can be possible. Moreover, by using hub or switcher, construction of multiple camera system can be easily performed.

2. Outstanding features

(1) Gigabit Ethernet interface

High-speed serial interface Gigabit Ethernet is supported and direct connection is possible to PC by the diameter cable of thin as compared with parallel output. Cable length can be extended to maximum 100m without hub and switcher.

(2) GigE Vision (Ver 1.00) correspondence

Based on Industrial camera interface standard GigE Vision, a maximum of 1Gbps high speed data transmit is available and suitable for image processing.

(3) GENiCAM (Ver 1.00) correspondence

Development of camera control system is easy because industrial camera control API "GENiCAM" lead EMVA (European Machine Vision Association).

(4) PoE correspondence

Power supply can be input via Ethernet cable (Power over Ethernet).

(5) Remote control

- Multi-step electronic shutter (from 1/90 to 1/50000 second in 8 steps)
- Variable shutter (from 10 to 1/100000 second)
- The image capture at desired timing using the external trigger signal and other various functions area set by remote control via a Gigabit Ethernet cable.

GigE Vision™ and the distinctive logo are trademarks of AIA (Automated Imaging Association).
GENiCAM™ is a trademark of EMVA (European Machine Vision Association).
Ethernet is a trademark of XEROX Corporation.

Hitachi Kokusai Electric

3. Specifications

(1) Imaging device	1/3-inch progressive scan interline CCD
Total number of pixels	692(H) x 504(V)
Effective pixels	656(H) x 494(V)
Pixel size	7.4 μ m (H) x 7.4 μ m (V) (Square pixel)
(2) Sensing area	4.88 mm (H) x 3.66 mm (V)
(3) Scanning system	Progressive
(4) Aspect ratio	4 : 3
(5) Frame rate	90 frames per second (fill pixel read out Mono 8bit)
(6) Sync system	Internal / external
(7) Lens mount	C mount
(8) Flange focal distance	17.526 mm
(9) Video output	
Interface	Gigabit Ethernet
Protocol	GigE Vision compliant
Transfer rate	1 Gbit per second
Image format	Mono 8/10/12 bit
Maximum image size	652(H) x 490(V)
Frame rate	90 fps frames per second
(10) Sensitivity	2000lx, F11, 3200K
(11) Minimum illumination	5lx (F1.4, Gain MAX)
(12) Electric shutter speed	OFF / Auto (AES) / Manual (PRESET or VARIABLE)
	OFF is normal exposure (frame rate)
	From 10 second to approx. 1/100,000 second
PRESET	1/90, 1/250, 1/500, 1/1000, 1/2000, 1/4000, 1/10000, 1/50000 second
VARIABLE	From 10 second to approx. 1/100000 second
(13) External trigger shutter	
Mode	Fixed shutter One trigger VD Sync Reset control
Input	Via Gigabit Ethernet cable (Software trigger) 12-pin connector (Hardware trigger)
Input level	High 5 to 24V Low 0 to 0.3V
Threshold	3.7V +/- 0.5V (Low --> High) 3.3V +/- 0.5V (High --> Low)
Input polarity	High / Low adjustable
Input delay	Adjustable

- (14) External sync signal
- | | |
|------------|----------------|
| VD output | 5Vp-p +/- 0.3V |
| Strobe out | 5Vp-p +/- 0.3V |
- (15) Partial scan Grabbing image area is adjustable at horizontal / vertical
- (16) V-binning OFF / ON
- (17) ALC (Auto level control) Adjustable for video level
- (18) Gain Auto / Manual (0dB to 18dB)
- (19) Gamma OFF ($\gamma=1$) / ON[
- (20) Sharpness Adjustable
- (21) Black level Adjustable
- (22) Knee Adjustable (Knee point and Knee slope)
- (23) Power supply DC+12V +/- 1V (input from 12-pin connector)
48 V (PoE)
- (24) Power consumption Approx. 4.3W (DC+12V)
When partial scan is on, Max Approx. 5.0W (DC+12V)
- (25) Ambient temperature
- | | |
|-------------|---|
| Performance | 0 to +40°C (+32 to +104 F), less than 90 % RH |
| Operation | -10 to +50°C (+14 to +122 F), less than 90 % RH |
| Storage | -20 to +60°C (-4 to +140 F), less than 70 % RH (without dew condensation) |
- Note : If operated continuously, be sure to use at less than +40°C (+104F)
for long term stable performance.
- (26) Vibration endurance 98.6 m/s² or less (10 to 200 to 15Hz, 30 minutes each on XYZ axes)
(Do not subject to strong vibration for long periods of time.)
- (27) Shock endurance 490.3 m/s² or less (vertical, horizontal, once each face)
- (28) External dimensions 44(W) x 29(H) x 72(D) mm (not including lens and protrusions)
- (29) Mass Approx. 140g

4. Composition

- (1) Camera (with Dummy glass)
- (2) CD-ROM (Operation manual, Control software)
- (3) Composition table

5. Optional accessories

- (1) Dummy glass (AR coated) ARC1214
- (2) IR cut filter IRC650
- (3) Junction box JU-F30
- (4) Tripod adaptor TA-M1
- (5) 12pin plug HR-10A-10P-12S(01)

(6) Camera cable

	Molded type	Shield type
2 m	C-201KSM	C-201KSS
5 m	C-501KSM	C-501KSS
10 m	C-102KSM	C-102KSS

In the CE Marking region, use the shield type and install clamp filter (ZCAT2035-0930A: TDK) at both ends of the cable.

- (7) LAN cable (Commercial item) CAT5E Straight cable
 CAT5E Cross cable
 CAT6 Straight cable
 CAT6 Cross cable

6. Specification of Digital output connector

(1) Gigabit Ethernet connector

PIN NO.	Signal
1	TRP1+
2	TRP1-
3	TRP2+
4	TRP3+
5	TRP3-
6	TRP2-
7	TRP4+
8	TRP4-

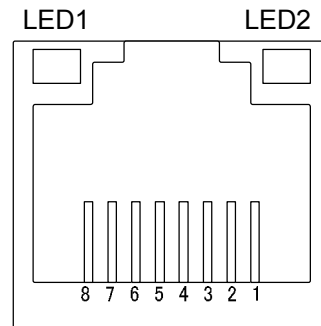

Connector : RJ-45

*LED Status

STATUS	LED 1	LED 2
Power ON	Green Light On	Orange Light On
1Gb transmission	Green Light On	Orange Blink On
100Mb transmission	Red Light On	Orange Blink On

(2) 12-pin connector

PIN NO.	Signal	PIN NO.	Signal
1	GND (+12V)	7	TRIG-A / VD (H)
2	+12V	8	TRIG-B (C)
3	GND	9	TRIG-B (H)
4	N.C.	10	FLASH / VD OUT
5	GND	11	N.C.
6	N.C.	12	TRIG-A / VD (C)

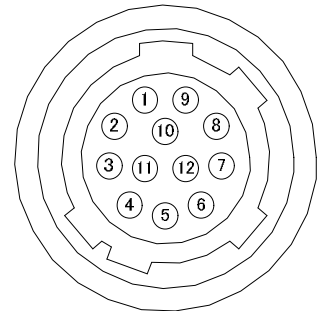

Connector (camera side) : SAMWOO SNH-10-12 (RPCB) or equivalent

Plug (matching cable plug) : Hirose HR10A-10P-12S (01) or equivalent

Please do not unplug and insert cable (camera cable) with a power supplied to a camera. Install clamp filter (ZCAT 2035-0930A: TDK) at both ends (camera and video processor ends) in the CE marking region.

Please do not connect 1 pin and 3/5 pin when using PoE. When connecting it, PoE may stop the power supply. Because TRIG-A/VD and TRIG-B are photo coupler input, 8/12 pin is isolated with 1/3/5 pin. When 8/12 pin is connected to GND, please connect to 3 pin or 5 pin.

Note: Please do not input any signal to N.C. pin because machine may break down.

7. Timing chart

7-1. Normal mode

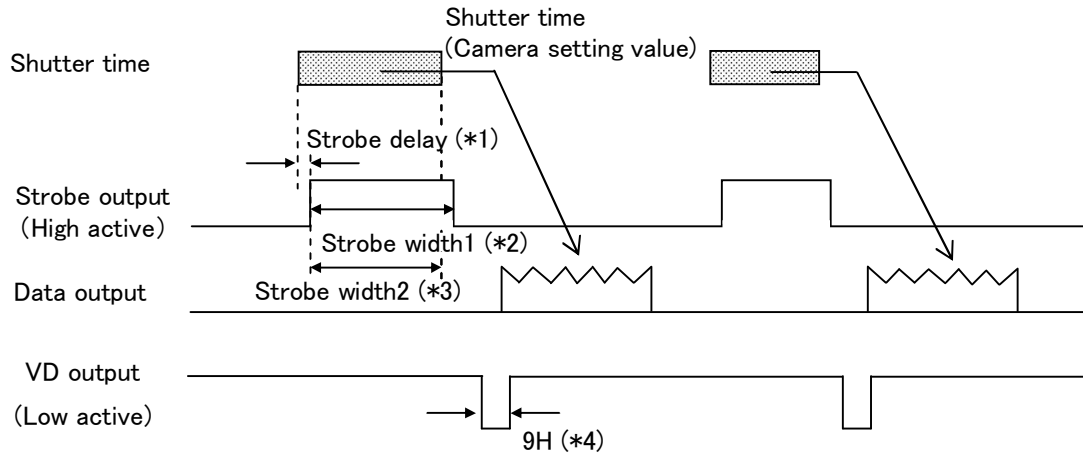

(*1) 0.22us to 13.1ms Approx. 3.2us/step

(*2) 3.2us to 13.1ms Approx. 3.2us/step

(*3) Shutter Time - Strobe delay (when duration time is set to 0)

(*4) 1H = Approx. 21.06us

Following graph shows frame rate in each width of picture grabbing when partial scan is ON.

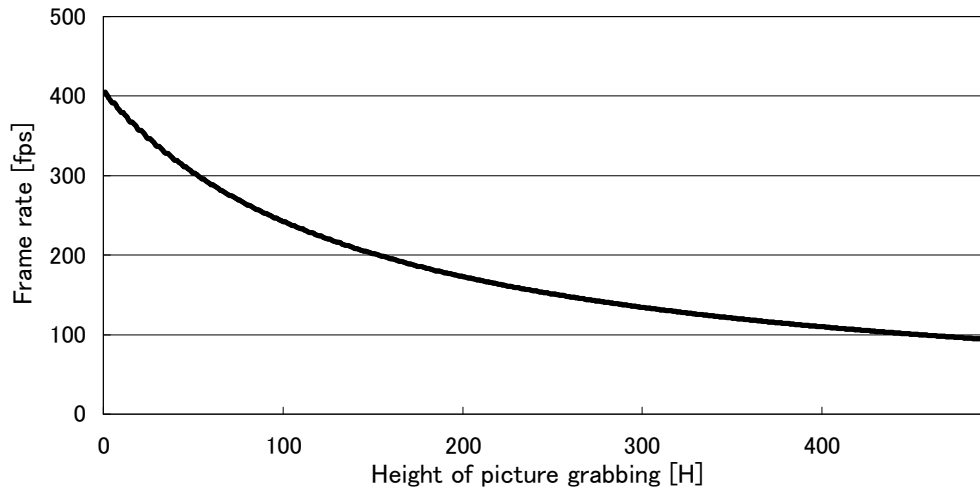

Note: Frame rate can be calculated from following equations using width of picture grabbing.

Total line = 17 + Width + (510 - Width) / 5 ... omit the figures after the decimal fractions

Frame rate = (37000000 / 768) / Total line

7-2. Fixed shutter mode

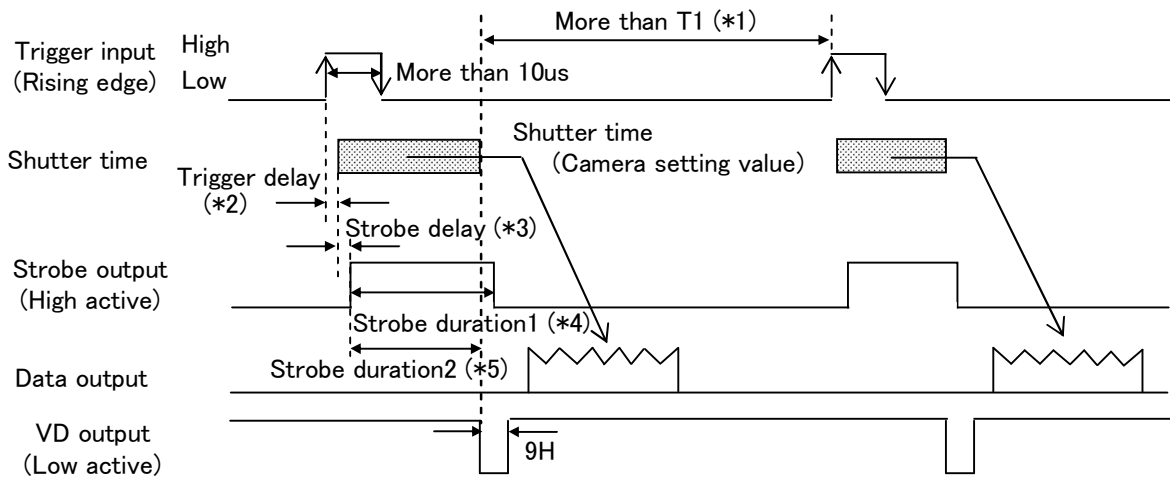

- (*1) $T1 = 1 / \text{Self frame rate [second]}$
- (*2) 3.62us to 13.1ms Approx. 3.2us/step
- (*3) 0.16us to 13.1ms Approx. 3.2us/step
- (*4) 3.2us to 13.1ms Approx. 3.2us/step
- (*5) Shutter Time - Strobe delay (when duration time is set to 0)

7-3. ONE Trigger mode

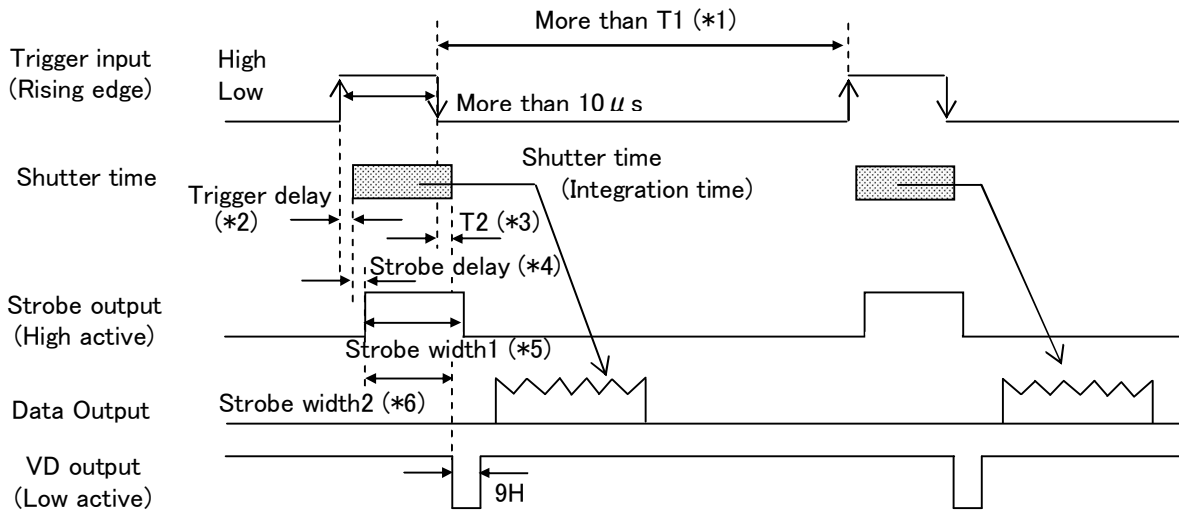

- (*1) $T1 = 1 / \text{Self frame rate [second]}$
- (*2) 3.67us to 13.1ms Approx. 3.2us/step
- (*3) $T2 = 30.13\text{us} + \text{Trigger delay}$
- (*4) 0.16us to 13.1ms Approx. 3.2us/step
- (*5) 3.2us to 13.1ms Approx. 3.2us/step
- (*6) Shutter Time - Strobe delay (when duration time is set to 0)

7-4. Reset control mode

(1) When Fixed shutter

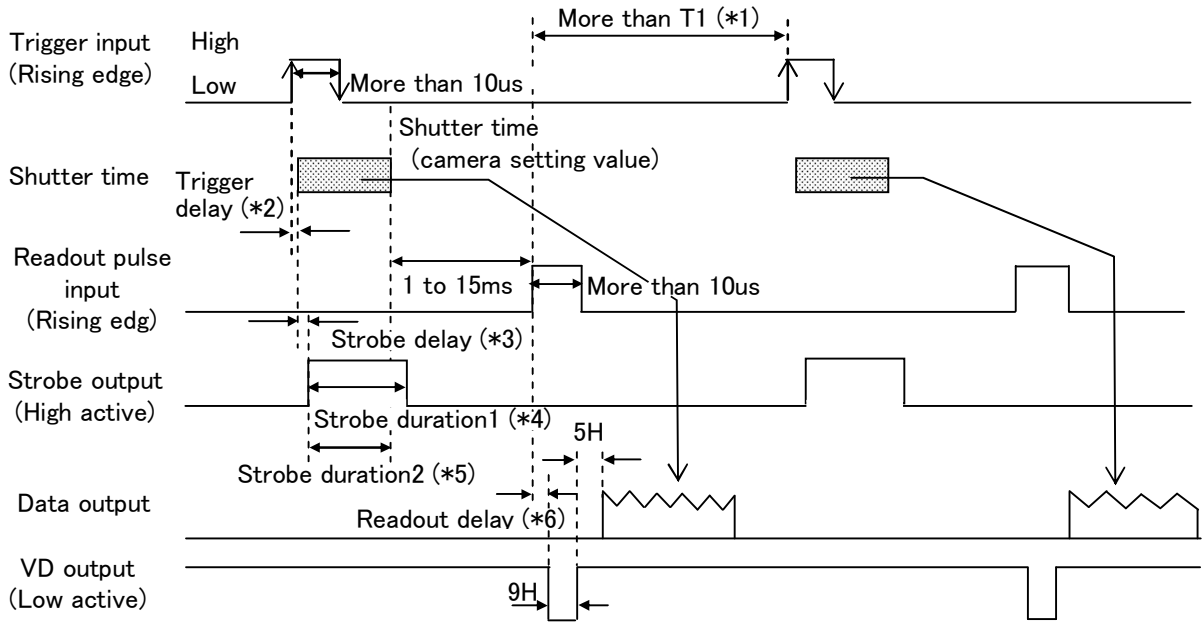

- (*1) $1 / \text{Self frame rate [second]}$
- (*2) 3.62µs to 13.1ms Approx. 3.2µs/step
- (*3) 0.16µs to 13.1ms Approx. 3.2µs/step
- (*4) 3.2µs to 13.1ms Approx. 3.2µs/step
- (*5) Shutter Time - Strobe delay (when duration time is set to 0)
- (*6) 43.9µs to 13.14ms Approx. 3.2µs/step

(2) When ONE Trigger

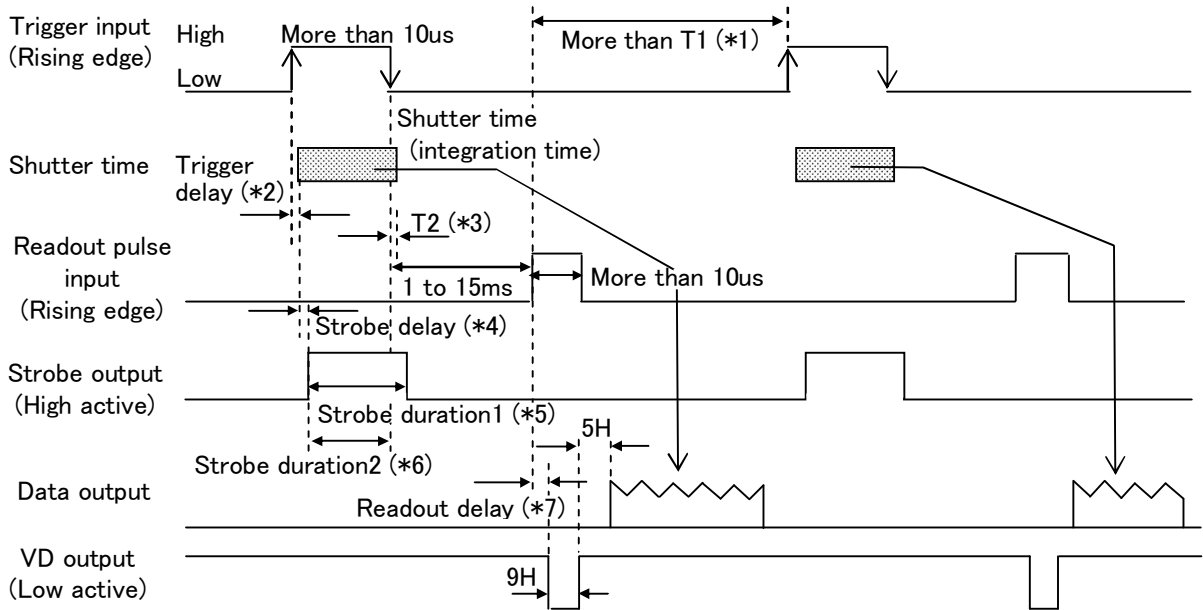

- (*1) $T1 = 1 / \text{Self frame rate [second]}$
- (*2) 3.2µs to 13.1ms Approx. 3.2µs/step
- (*3) $T2 = 30.13\mu\text{s} + \text{Trigger delay}$
- (*4) 0.16µs to 13.1ms Approx. 3.2µs/step
- (*5) 3.2µs to 13.1ms Approx. 3.2µs/step
- (*6) Shutter Time - Strobe delay (when duration time is set to 0)
- (*7) 45.8µs to 13.1ms Approx. 3.2µs/step

Special function of reset control mode

The camera shifts to the output of a normal mode (continuous output) when Trigger input signal passes about 1/3 second in the state of High.

It returns to the Trigger mode if Trigger input signal becomes Low.

However, after becoming Low Trigger input, the period of 50ms becomes a Trigger signal input prohibition period.

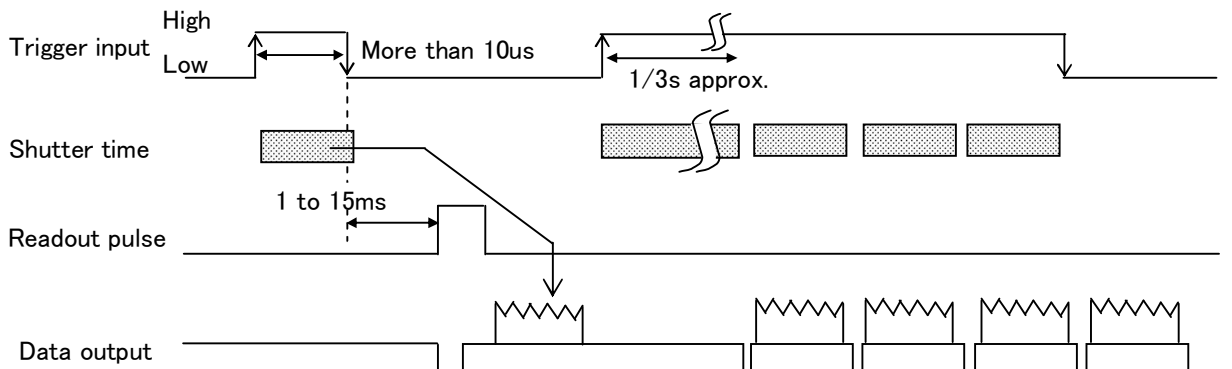

7-5. VD reset mode

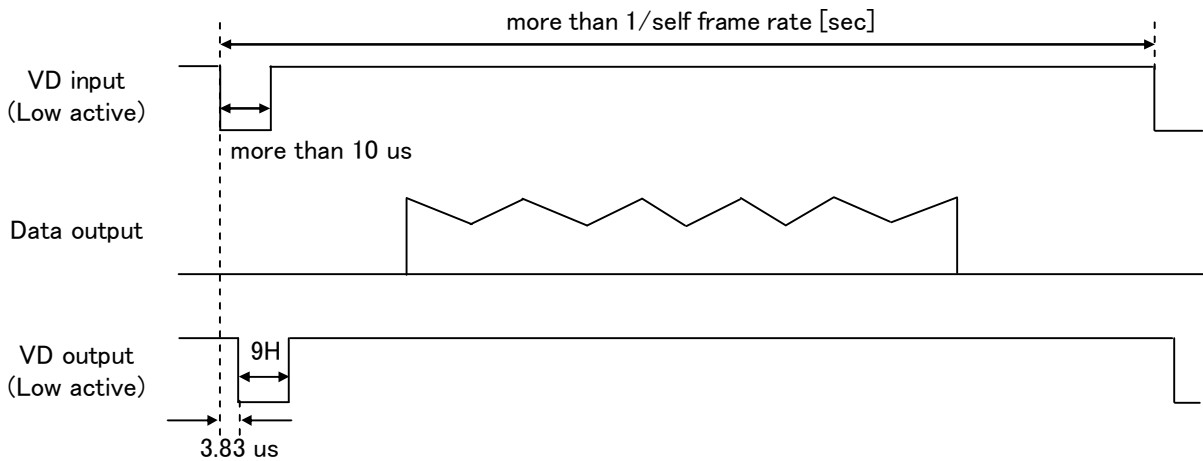

NOTE: If the external VD of cycle which does not match the camera operation mode is input, shutter time has an error.

8. Input/Output signal

(1) Input signal

The level of the trigger signal input to the camera is as follows.

- High level : +5.0 to +24V
- Low level : 0 to +0.3V
- Threshold : 3.7V +/- 0.5V (Low --> High)
3.3V +/- 0.5V (High --> Low)

(2) Output signal

The level of the strobe / VD signal output from the camera is as follows.

- High level : +5V
- Low level : 0V

9 Spectral response

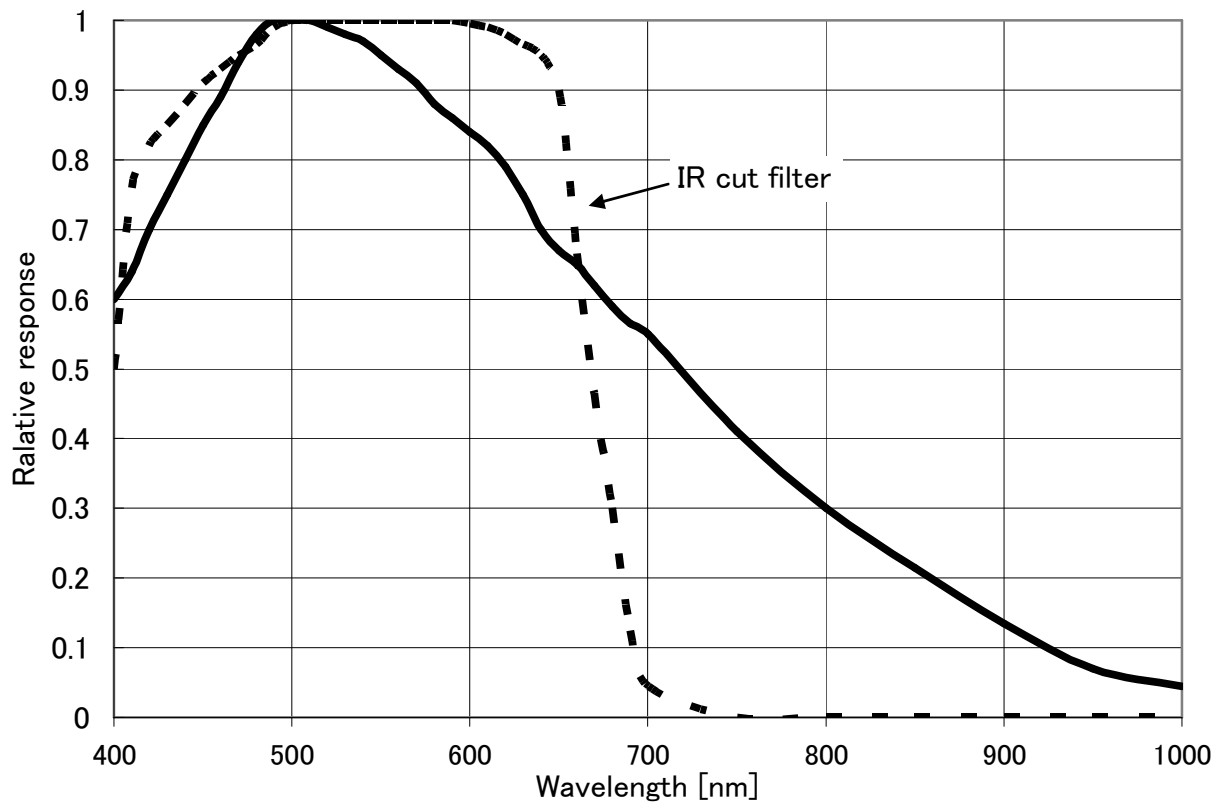

10. External view

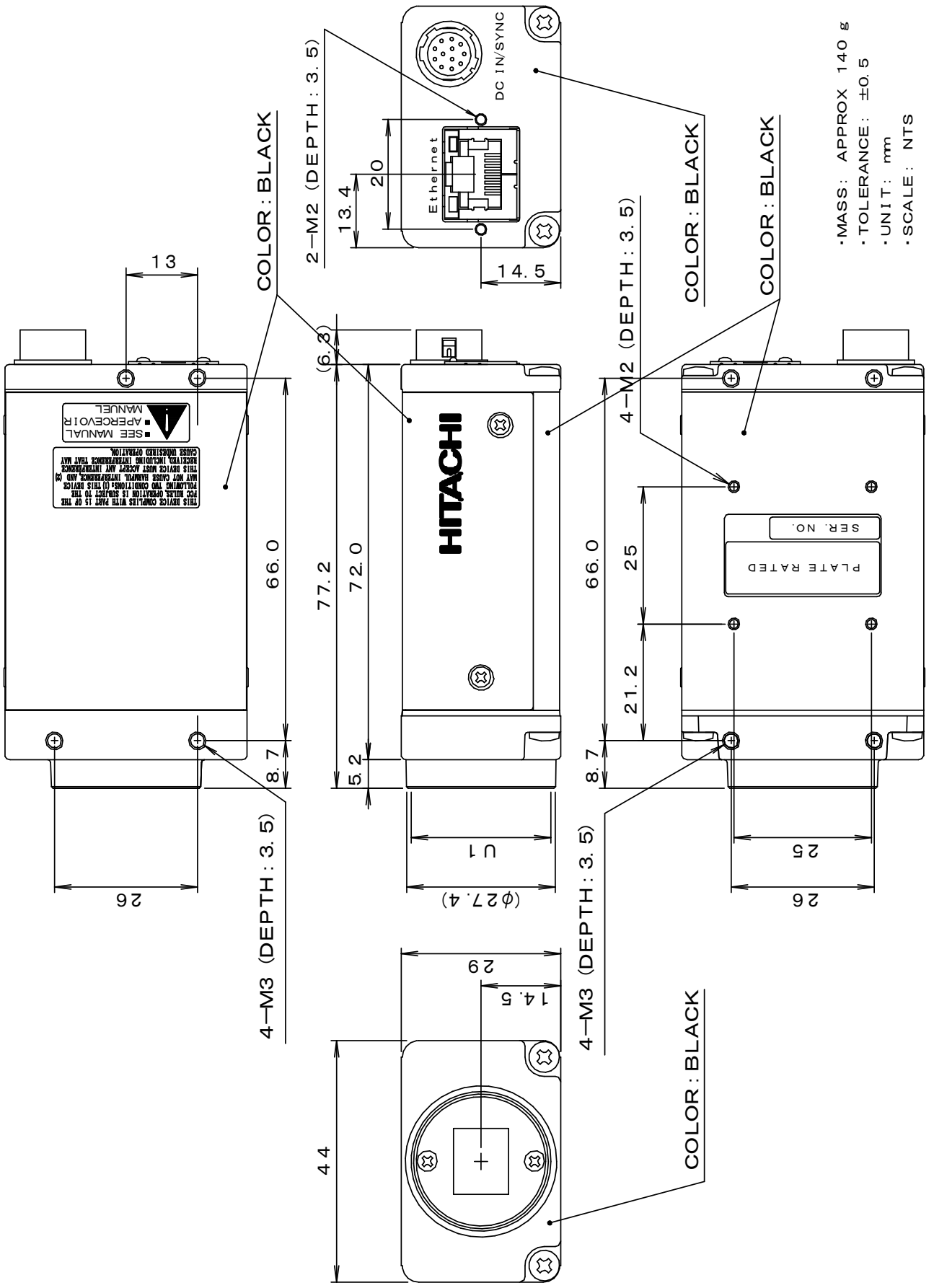

- MASS: APPROX 140 g
- TOLERANCE: ± 0.5
- UNIT: mm
- SCALE: NTS

Notice:

These specifications are subject to change without prior notice due to product improvement. Confirm the most recent specifications at time of order.

Hitachi Kokusai Electric certifies this product complies with the standard warranty conditions of Hitachi Kokusai Electric, and that quality control is implemented to the extent required to comply with these conditions.

RoHS Compliant

This product complies with the requirement of the RoHS (Restriction of the use of Certain Hazardous Substances in Electrical and Electronic Equipment) Directive 2002/95/EC

Warranty and service:

- 1) The guarantee period is two year after the date purchase. However, the defects due to erroneous use or intentional act are excluded.
- 2) As the defect after expiration of the guarantee period, where product repair is possible, repair will be performed at charge.
- 3) The present Warranty pertains only to the camera unit. Secondary malfunctions attributable to camera failure as well as expenses incurred by disassembly and reassembly of the related system, are beyond the scope of this Warranty.
- 4) Compensation for loss of business, loss or damage to software, database and other contingent losses are beyond the scope of this Warranty.
- 5) Hitachi Kokusai Electric Inc. is not liable for the losses caused when the equipment is used in a system, use for business trades, production process, medical fields, crime prevention applications, etc.
- 6) The parts used in the equipment have their respective lives. The lives of such parts will be shortened under the environments of high temperature or high humidity. When the stable operation is required for a long time, it is recommended to perform periodical maintenance and inspection every year or every two years.