

IEEE1394.b
Progressive Scan CCD Camera
KP-F32F
Specifications

Hitachi Kokusai Electric Inc.

1. General

The KP-FD32F is single CCD type camera which utilized the progressive scan CCD image sensor with square pixel for VGA format of 1 / 2-inch.

By adoption of an IEEE1394.b interface, high-speed connection of maximum of 800 Mbps can be possible. Moreover, by daisy chain, construction of multiple camera system can be easily performed.

2. Principal features

1) High resolution

The 1/2-inch 320,000 pixels square lattice progressive scan CCD and achieve a high resolution of 656(H) x 494(V) (VGA).

2) IEEE1394.b interface

High-speed serial interface IEEE1394.b is supported and direct connection is possible to PC by the diameter cable of thin as compared with parallel output. It is possible to be supplied power and trigger by one cable, and connectable to a 4sets/port by daisy chain.

3) IIDC1.31 correspondence

Based on uncompressed data protocol IIDC1394-based Digital Camera Specification Ver.1.31, a maximum of 800Mbps high speed data transmit is available and suitable for image processing.

4) Various output formats

Various output formats are available, such as the high quality picture format and the high frame rate for multiple connection picture format, according to the usage and the situation.

Ex. VGA: 640(H) x 480(V) / Mono8bit / 60fps
 VGA: 640(H) x 480(V) / Mono8bit / 30fps x 4 sets

5) A daisy chain

The KP-FD32F have two IEEE1394.b connectors, it can link together cameras. Since one PC and the minimum number of cable can control the plural camera, simple system integration can be realized.

6) CCD drive functions

·Auto electronic Shutter mode (AES)

Adjusted automatically from approx. 1/100,000 second to 10 second.

·Variable electronic shutter mode

Variable from approx. 1/100,000 second to 10 second.

7) External trigger

An external trigger signal input can be used to capture an image at desired timing for instant view or processing. The software trigger via an IEEE1394 cable and our original system corresponding to the hardware trigger can deal with all trigger signals.

3. Specifications

- 1) Imaging device : 1/2-inch progressive scan interline CCD
(with on-chip microlenses)
 - Total number of pixels : 692(H) x 504(V)
 - No. of effective pixels : 656(H) x 494(V)
 - Unit cell size : 9.9(H) x 9.9(V) μm (Square pixel)
- 2) Scanning system : Progressive scan
- 3) Sync system : Internal / external
- 4) Video signal output
 - Interface : IEEE1394.b (FireWire 800)
 - Protocol : IEEE1394-based Digital Camera Specification Version 1.31 compliant
: 800 / 400 / 200Mbps
 - Image format : Mono8 / Mono16
 - Image size : 656(H) x 492(V)
640(H) x 480(V)
 - Frame rate : 60fps (Condition: Mono8, 640(H) x 480(V))
- 5) Camera remote : IEEE1394 control
- 6) Standard sensitivity : 2000lx F5.6
- 7) Minimum illumination : 10 lx (F1.4, Max gain)
- 8) Gain : Auto / Manual (0dB to 18dB)
- 9) Electric shutter speed : Auto (AES) / Manual (VARIABLE)
From 1/100,000 second to 10 second
- 10) External trigger shutter : Mode Fixed shutter (Mode 0)
One trigger (Mode 1)
Reset control (Mode 14)
VD Sync (Mode 15)
Input Via IEEE1394 cable (Software trigger)
Our company original method (Hardware trigger)
Input level 5Vp-p plus minus 1V
- 11) External sync signal VD output 5Vp-p plus minus 0.3V
Strobe out 5Vp-p plus minus 0.3V
Through out 5Vp-p plus minus 0.3V
- 12) Auto Exposure (ALC: Auto level control)
: Adjustable for video level
- 13) Gamma : OFF / LUT
- 14) Sharpness : Adjustable
- 15) Brightness : Adjustable
- 16) Time stamp : OFF / ON

- 17) Cycle timer sync : OFF / ON
- 18) HD reset : OFF / ON
- 19) Daisy chain : Possible, Even if there is no repeater.
It two is connected, the frame rate becomes half.
- 20) Lens mount : C mount (Flange-back adjustment)
- 21) Power supply : DC+8V to +30V (Via IEEE1394 cable)
- 22) Power consumption : Approx. 3.5W (DC+12V)
- 23) Ambient temperature
- Operating : -10 °C to +50 °C / 30 to 80 %RH
- Note : If operated continuously, be sure to use at less than +40 °C(104F)
for long term stable performance.
- Storage : -20 °C to +60 °C / 20 to 90 %RH
- 24) Vibration endurance : 68.65 m/s² or less
(10 to 200Hz, 30 minutes each on XYZ axes)
(Do not subject to strong vibration for long periods of time.)
- 25) Shock endurance : 490.3 m/s² or less (vertical, horizontal, once each face)
- 26) External dimensions : 44(W) x 44(H) x 54(D) mm
(not including lens and protrusions)
- 27) Mass : Approx. 130g (without lens)
- 28) Supplied equipment : Camera
CD-ROM (Operation manual / Driver soft)
- 29) Optional accessories : IEEE1394 cable (with Locked mechanism)
Tripod adopter (TA-FD140)

4. Video format

A. Fixed format

				Frame Rate					
Format	Mode	Image Size	Color Coding	60	30	15	7.5	3.75	1.875
0	5	640 x 480	YMONO8	○	○	○	○	○	○
	6	640 x 480	YMONO16	○(*)	○	○	○	○	○

B. Free format (Format7)

Format	Mode	Image Size	Color Coding	Packet Size [Byte]			
7	0	656 x 492	YMONO 8	7872 (*)	5904 (*)	3936	1968
		656 x 492	YMONO 16	7872 (*)	5904 (*)	3936	1968
	1	640 x 480	YMONO 8	7680 (*)	5760 (*)	3840	1920
		640 x 480	YMONO 16	7680 (*)	5760 (*)	3840	1920

(*): required S800 data rate

5. Rear panel and pin assignment

REAR PANEL

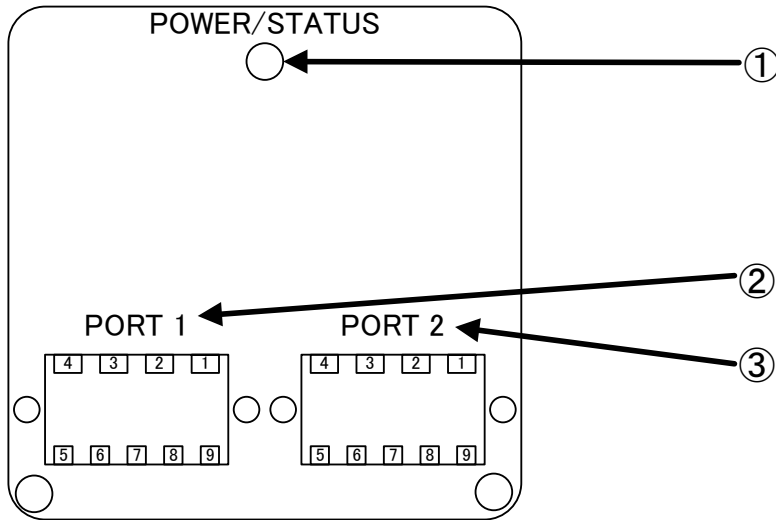

①POWER/STATUS LED

LED status

LED	Green	Yellow
Power ON	light on	light off
Transmission	blink off	blink on
Transmission pause	blink on	blink off

②IEEE1394b connector

③IEEE1394b connector

Signal connection to IEEE 1394.b(PORT1/PORT2)

1	TPB-	SERIAL DATA
2	TPB+	
3	TPA-	
4	TPA+	
5	TPA(R)	SHIELD GND
6	VG	POWER GND
7	I/O	*Programmable I/O
8	VP	POWER +12V
9	TPB(R)	SHIELD GND

Viewer Soft Setting(PORT1/PORT2)

*Programmable I/O	In	Out
Trigger	○	○
VD	○	○
Strobe (Flash)	×	○

6. Timing chart

a) Digital Out

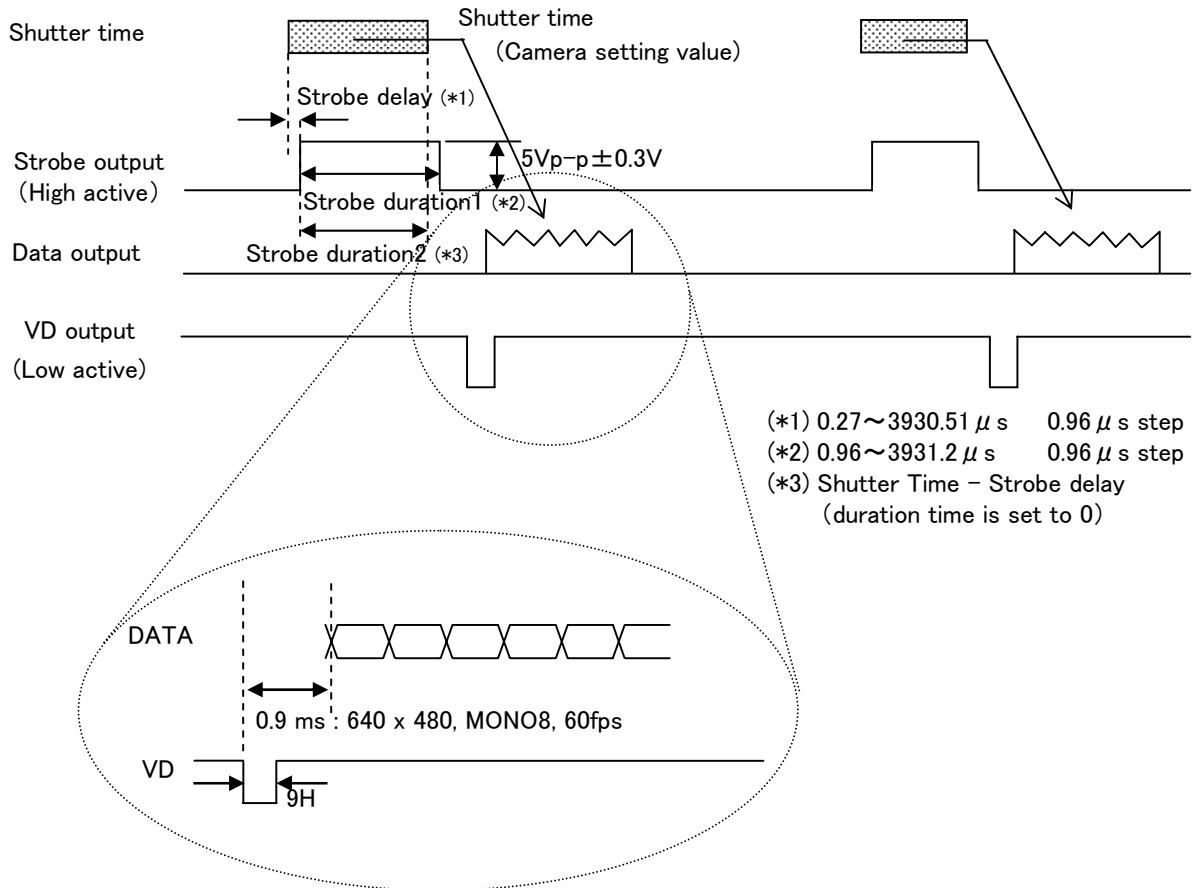

b) Fixed shutter mode

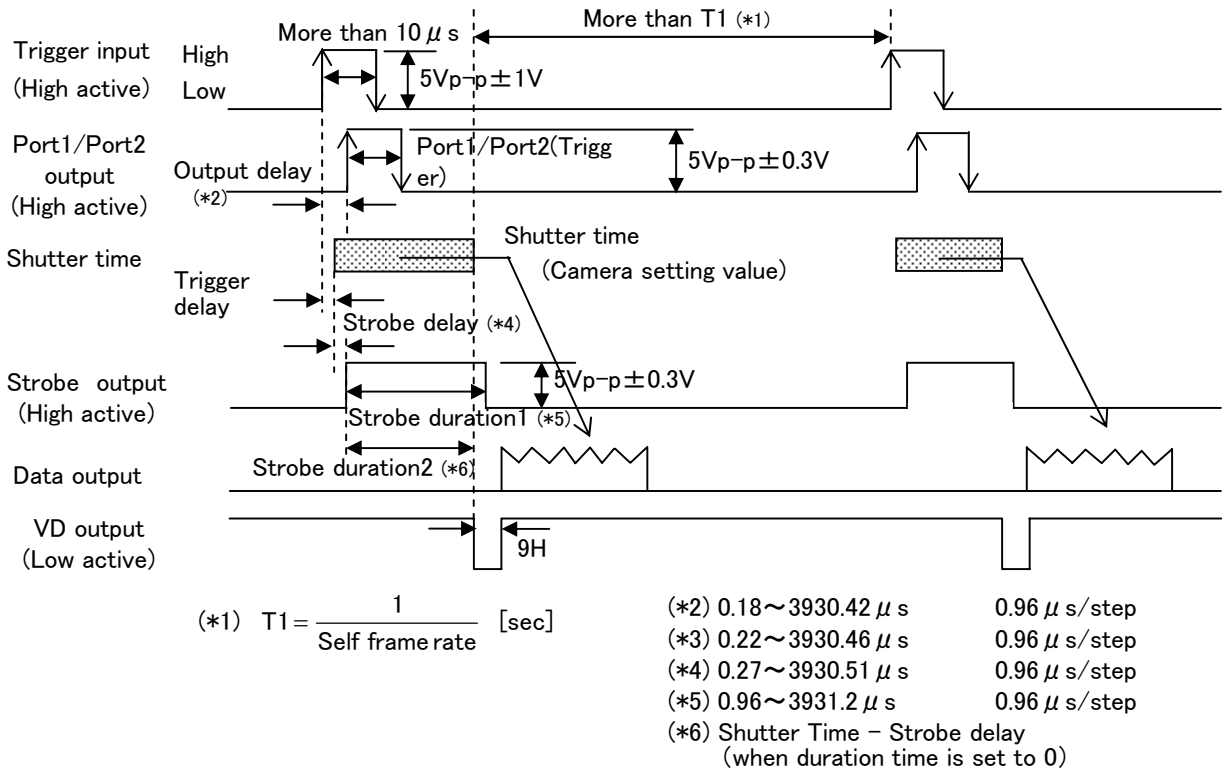

c) One-trigger mode

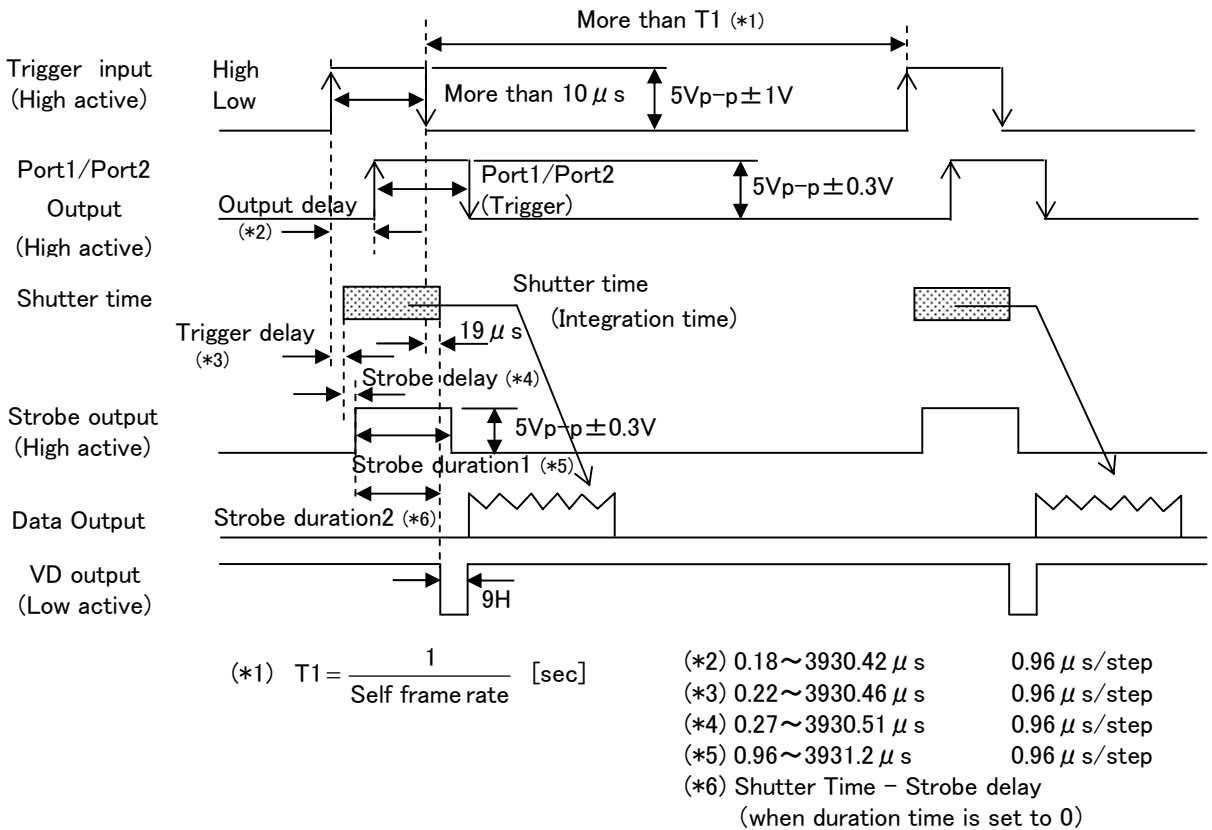

d) Rest control

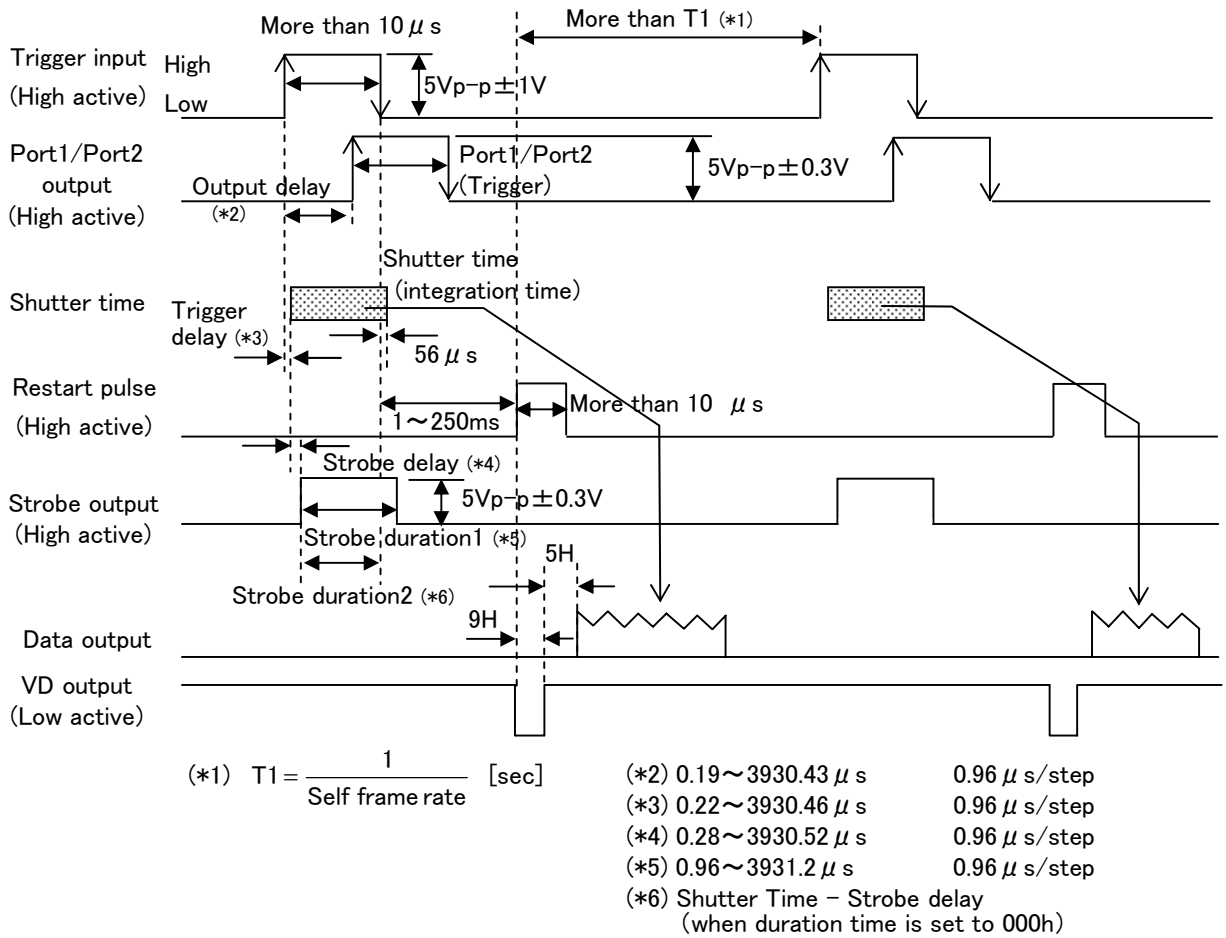

Note: Special function of reset control Trigger

The camera shifts to the output of a normal mode (continuous output) when Trigger signal passes about 1/3 seconds in the state of High. (The image is output by inputting the Trigger at the VD cycle for this period.)

It returns to the Trigger mode if Trigger signal becomes Low. However, after becoming Low Trigger, the period of 100ms becomes a Trigger signal input prohibition period.

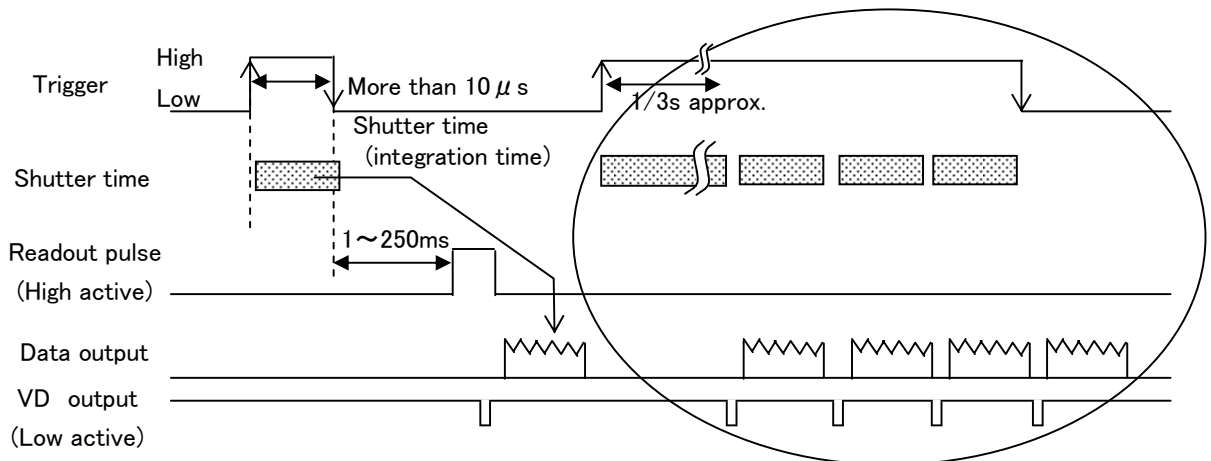

e) VD Sync

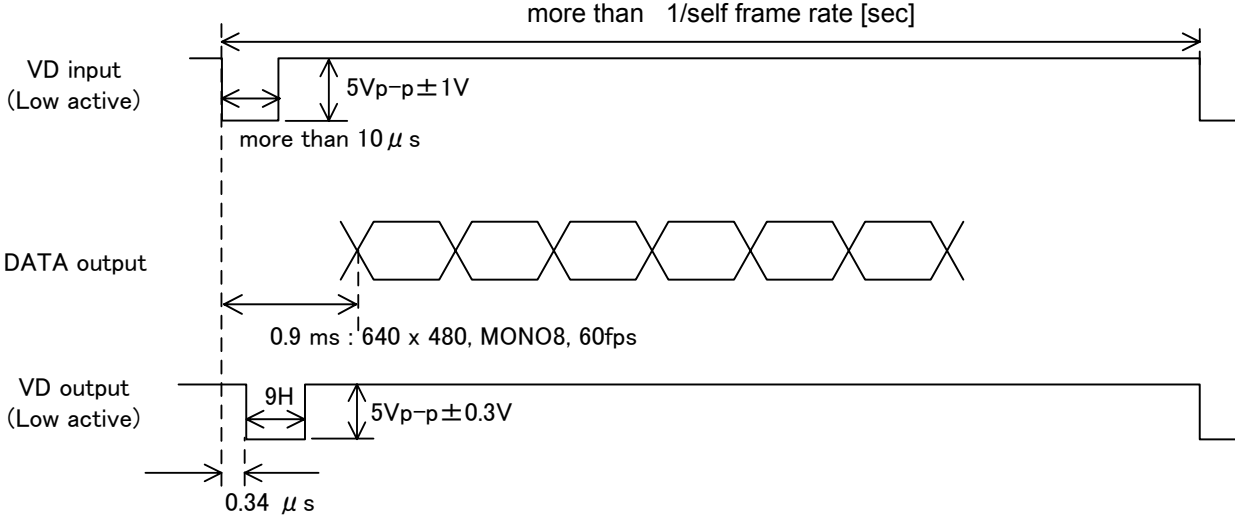

7. External View

- UNIT : mm
- MASS : APPROX 130 g

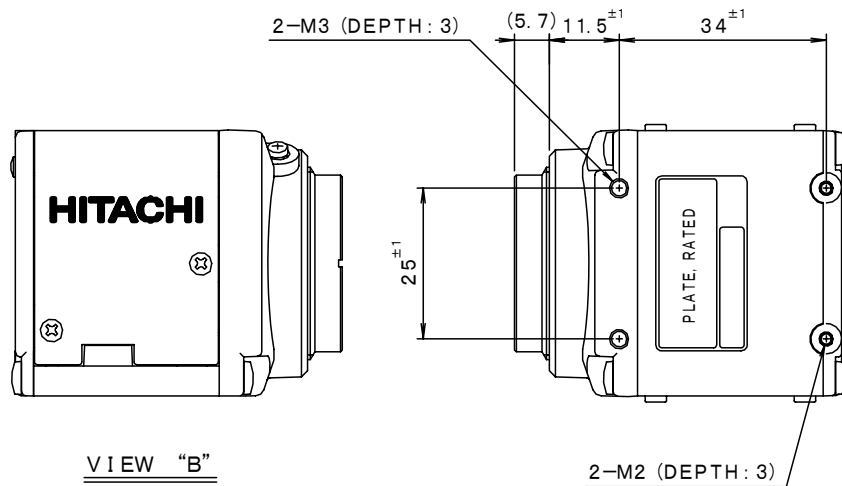
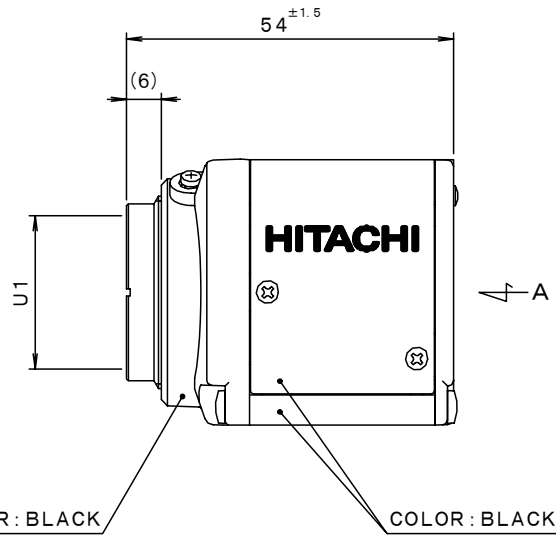
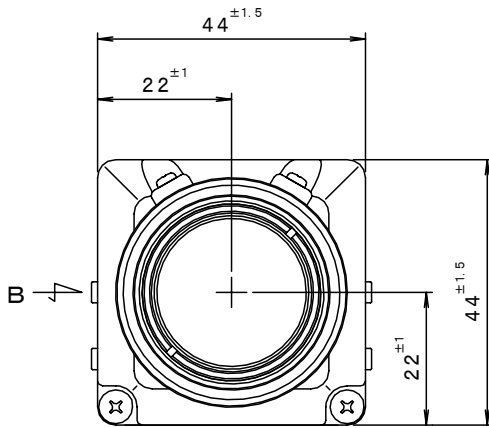
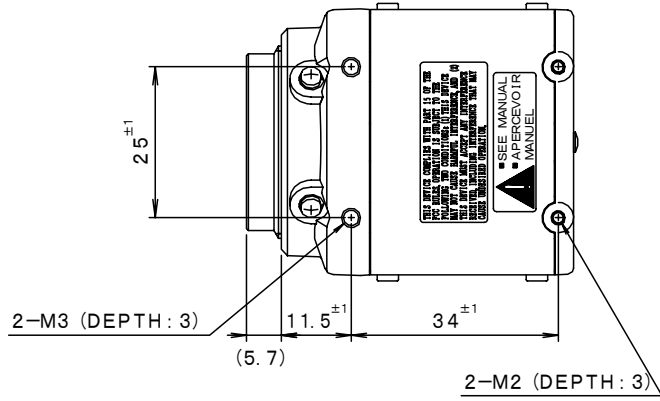
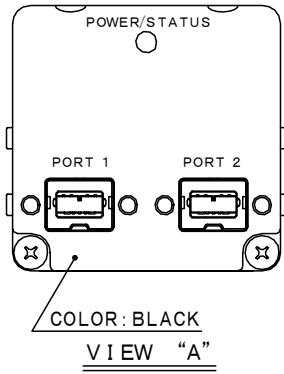

Notice:

These specifications are subject to change without prior notice due to product improvement. Confirm the most recent specifications at time of order.

Hitachi Kokusai Electric certifies this product complies with the standard warranty conditions of Hitachi Kokusai Electric, and that quality control is implemented to the extent required to comply with these conditions.

Warranty and service:

- 1) The guarantee period is one year after the data purchase. However, the defects due to erroneous use or intentional act are excluded.
- 2) As the defect after expiration of the guarantee period, where product repair is possible, repair will be performed at charge.
- 3) The present Warranty pertains only to the camera unit. Secondary malfunctions attributable to camera failure as well as expenses incurred by disassembly and reassembly of the related system, are beyond the scope of this Warranty.
- 4) Compensation for loss of business, loss or damage to software, database and other contingent losses are beyond the scope of this Warranty.
- 5) Hitachi Kokusai Electric Inc. is not liable for the losses caused when the equipment is used in a system, use for business trades, production process, medical fields, crime prevention applications, etc.
- 6) The parts used in the equipment have their respective lives. The lives of such parts will be shortened under the environments of high temperature or high humidity. When the stable operation is required for a long time, it is recommended to perform periodical maintenance and inspection every year or every two years.