

1

2

3

4

A

B

C

D

E

F

HV-F31CL Color Camera Specifications

DWN	A. Kato	05-02-18	HV-F31CL Color Camera Specification (1/14)	Hitachi Kokusai Electric Inc. Tokyo Japan	
DSGN	A. Kato	05-02-18			
CHKD	S. Ikeda	05-02-18			
APPD	T. Inoue	05-02-18			

1

2

3

1. Introduction

The Hitachi HV-F31CL is a XGA high precision 3CCD progressive scan color camera, which has single chip digital processing LSI, a C mount prism, three 1/3-inch 800,000 pixels square CCDs, and a Camera Link interface.

A newly developed multi-functional LSI use the accurate 14 bit digital processing technology, which performs the high picture quality signal processing and the picture compensating functions, beyond the capability of the other conventional analog cameras.

The Camera Link interface that is the standard of the digital camera for FA makes it possible to transmit large capacity digital data effectively with less cable number than a conventional RS-644 method.

2. Features

1) High resolution

The 1/3 inch 800,000 pixels progressive scan CCD and the accurate CCD matching technology achieves a high-resolution image of 1024 H x 768 V (XGA).

2) Camera Link interface

Based on the medium configuration of Camera Link, which includes the digital video signal of 30 bits RGB, an external trigger input, and camera control signal (RS-232C).

Note: A frame grabber board and two cables for Camera Link are optional.

3) Camera signal processor is single chip LSI.

The Hitachi's most advanced technology (0.18 um design process, 1.8V internal core drive voltage) produces a single newly developed ultra LSI chip (3 million gates), and contributes to the downsizing and the low power of the camera.

In addition, the 12-bit A/D converter and 14 bit internal processor provide high S/N and wide dynamic range.

DWN		.	.	HV-F31CL Color Camera Specification (2/14)	Hitachi Kokusai Electric Inc. Tokyo Japan	
DSGN		.	.			
CHKD		.	.			
APPD		.	.			

4) C mount lens adapter

The de facto industry standard C mount lens adapter allows choosing from a various type of lenses and optical systems.

5) Digital processing for various picture quality enhancements

- Independent six colors masking is the Hitachi innovation for optimizing color balance. The saturation and the hue of 6 colors (Red, blue, green, cyan, magenta and yellow) are adjusted independently to deliver the best color in image capture, microscope and other applications.
- Variable sharpness (detail) width function optimizes the width of image contours. The bold contours show the picture clear, while the thin contours show it natural.

6) Auto shading correction (ASC)

Color shading due to the aberration of C mount lens is automatically compensated (reduced).

7) Versatile CCD drive functions

- Video frame capture on demand using external trigger signal.
See detailed specifications item 7.
- Long integration mode.
- Auto electronic shutter (AES) mode for stabilized video level.

DWN	/	.	.	HV-F31CL Color Camera Specification (3/14)	Hitachi Kokusai Electric Inc. Tokyo Japan	
DSGN	/	.	.			
CHKD	/	.	.			
APPD	/	.	.			

8) Versatile imaging functions

- Four application files.

User settings provided for sharpness(detail), masking etc.

- Scene color temperature is detected in dynamic for automatic white balance adjustment.

By varying the detection area in a scene, the whole white balance can be controlled in only the area. Thus, even if a light source of a different color temperature enters the scene (e.g., situation often occurs in a retail showroom suddenly exposed to outdoor lighting when the entrance door opens), white balance is not severely disturbed.

- Auto exposure (ALC : auto level control)

Light strength is measured in divided 64 areas, combined with continued control of AGC and AES, to provide extremely wide response to light variations. The fine level and peak or average of ALC response can be set from menu.

- Focus data output (serial data)

- Two mode gain control

AGC or user-programmable gain in 1 dB steps

- Contrast function

- Flare compensation

- Master black, R/B black, and R/B gain are variable.

- Color bar

- Selectable negative/positive image

9) LED indicator

Camera rear panel has a LED indicator for power on/off.

3. Standard composition

3.1 HV-F31CL camera 1

3.2 Accessories

1) Lens mount sheet 1

2) DC IN/SYNC connector plug (HR10A-10P-12S) 1

3) CD-ROM 1

(includes a camera control software for evaluation
and a supplement manual)

4) Operation manual 1

DWN	/	· ·	HV-F31CL Color Camera Specification (4/14)	Hitachi Kokusai Electric Inc. Tokyo Japan	
DSGN		· ·			
CHKD		· ·			
APPD		· ·			

4. Specifications

1)	Optical system	1/3-inch F2.2 prism	A
2)	Imaging system	RGB 3 CCD	
3)	Imaging device	1/3-inch interline CCD	
	Total pixels	1077 (H) x 788 (V)	
	Effective pixels	1024 (H) x 768 (V)	
	Effective image area	4.76 (H) x 3.53(V) mm	
4)	Scanning system	Progressive scan	
5)	Sync system	Internal/external (automatically switched by HD/VD)	B
6)	Standard sensitivity	2000 lx, F5.6 (at 1/30s shutter speed)	
7)	Gamma correction	0.45/1.0 (on/off)	
8)	Picture distortion	Full screen 0% (not including lens response)	
9)	Registration	Full screen 0.05% (not including lens response)	
10)	Vertical contour correction	2H	
11)	Lens mount	C mount (flangeback: 17.526 mm in air)	
12)	Sensitivity selection	AGC (0 to +12 dB) or 1 dB steps	
13)	Sharpness(detail) control functions	Level, width	C
14)	CCD drive functions		
	Variable shutter mode	: 1/30 to approx. 1/100,000 second	
	AES mode	: Off to approx. 1/100,000 second	
	Long time integration mode	: 1/30 to approx. 4 seconds in 1 frame steps	
16)	Color bar	Full	
17)	Power supply voltage	12 VDC nominal (Stable operation from 10.5 to 15 VDC, without ripple and noise.)	D
18)	Power consumption	Approx. 6 W	
19)	Dimensions	65 (W) x 65 (H) x 130 (D) mm	
20)	Mass	Approx. 600 g (not including lens)	
21)	Recommended ambient temperature, operating	0 to +40 °C	
22)	Recommended ambient temperature, storage	-20 to +60 °C	E

DWN	/	· ·	HV-F31CL Color Camera Specification (5/14)	Hitachi Kokusai Electric Inc. Tokyo Japan		F
DSGN		· ·				
CHKD		· ·				
APPD		· ·				

5. Input and output signals

5.1 Camera Link connector

- 1) Conformance standard
Medium configuration of Camera Link
- 2) Video signal output
RGB 30bit
- 3) Video sync signal output
 - Horizontal frequency (LVAL) : 23.72 kHz
 - Vertical frequency (FVAL) : 29.95 Hz
 - Pixel clock : 28.8 MHz
- 4) Camera control signal input/output ^(Note 1)
RS-232C protocol [LVDS level]

5.2 DC IN/SYNC connector

- 1) External sync input ^(Note 2)
 - HD/VD 2 to 5 V_{p-p}, negative polarity
- 2) External trigger input (Photo-coupler input) ^(Note 3)
 - Trig in low 0 VDC, high 3 to 24 VDC
- 3) Strobe sync signal output
 - Flash out low 0 VDC, high 5 VDC
- 4) Power supply input
 - 10.5 to 15 VDC , 6.5W
- 5) Camera control signal input/output ^(Note 1)
 - RS-232C protocol
 - RXD input level: low -3 to -15 V, high 3 to 15 V
 - TXD output level: low -5 to -9 V, high 5 to 9 V

5.3 TRIG IN connector ^(Note 3)

Only external trigger signal can be supplied even with BNC cable

(Switched DC in/Sync by connector Trig in and command)

- Trig in low 0 VDC, high 2 to 5 VDC

(Note 1) Either Camera Link connector or DC IN/SYNC connector are available for camera control signal input/output (selectable by internal switch).

(Note 2) When camera control signal input/output is used via DC IN/SYNC connector, external sync input is unavailable.

(Note 3) Either DC IN/SYNC connector or TRIG IN connector are available for external trigger input.

DWN	/	• •	HV-F31CL Color Camera Specification (6/14)	Hitachi Kokusai Electric Inc. Tokyo Japan	
DSGN		• •			
CHKD		• •			
APPD		• •			

6. Camera Link output timing chart

6.1 Horizontal sync and video timing

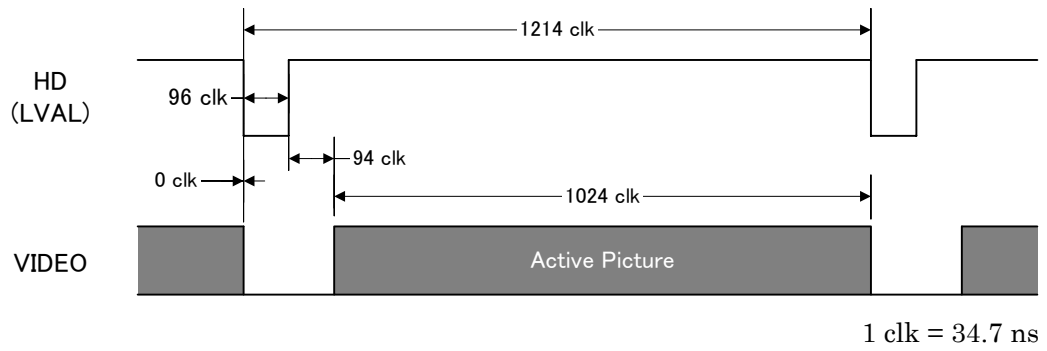

6.2 Vertical sync and video timing

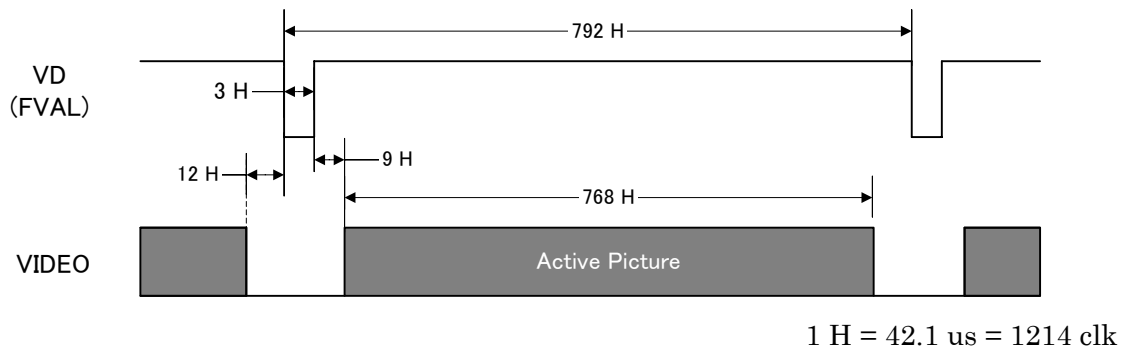

DWN	/	.	.
DSGN		.	.
CHKD		.	.
APPD		.	.

HV-F31CL
Color Camera
Specification (7/14)

Hitachi Kokusai Electric Inc.
Tokyo Japan

6.3 Transmitter LVDS output pulse position

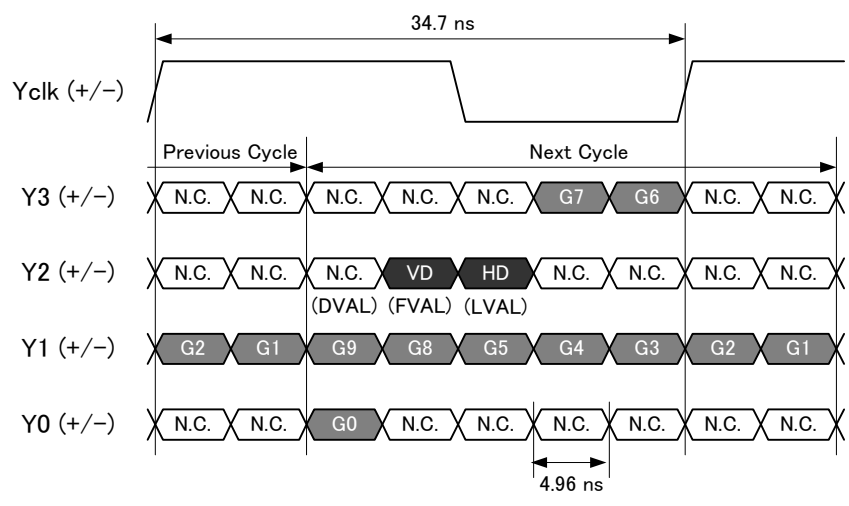
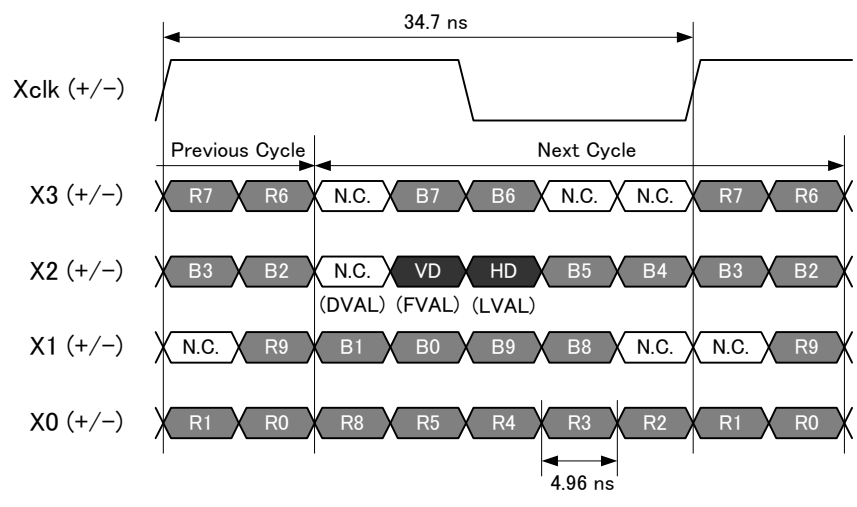

DWN	/	.	.	HV-F31CL Color Camera Specification (8/14)	Hitachi Kokusai Electric Inc. Tokyo Japan	
DSGN		.	.			
CHKD		.	.			
APPD		.	.			

7. External trigger timing chart

7.1. Pulse width control exposure mode

The exposure time is controlled by the width of external trigger, and 1 frame image is output when the reset timing of VD signal.

The minimum exposure time is 1/ 10,000 seconds even with minimum trigger width.

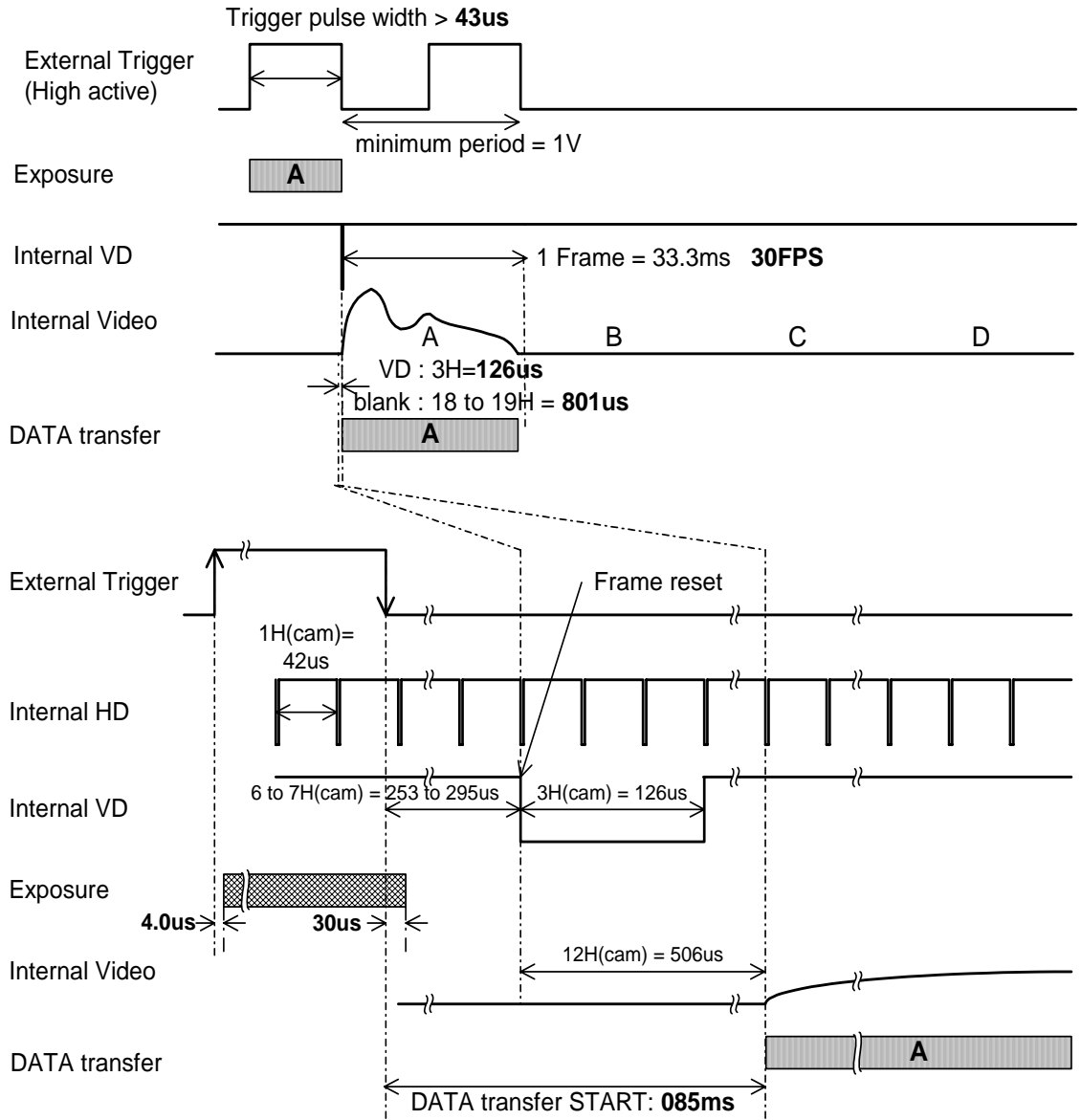

DWN	/	.	.
DSGN	/	.	.
CHKD	/	.	.
APPD	/	.	.

HV-F31CL
Color Camera
Specification (9/14)

Hitachi Kokusai Electric Inc.
Tokyo Japan

A

B

C

D

E

F

7.2. Pre-selected exposure mode

When the external trigger signal is input, a flash signal is output after the end of trigger signal. When the VD signal of the camera is reset after the end of flash signal, 1 frame image is output. The output timing of a flash signal against the trigger signal can be set on the camera

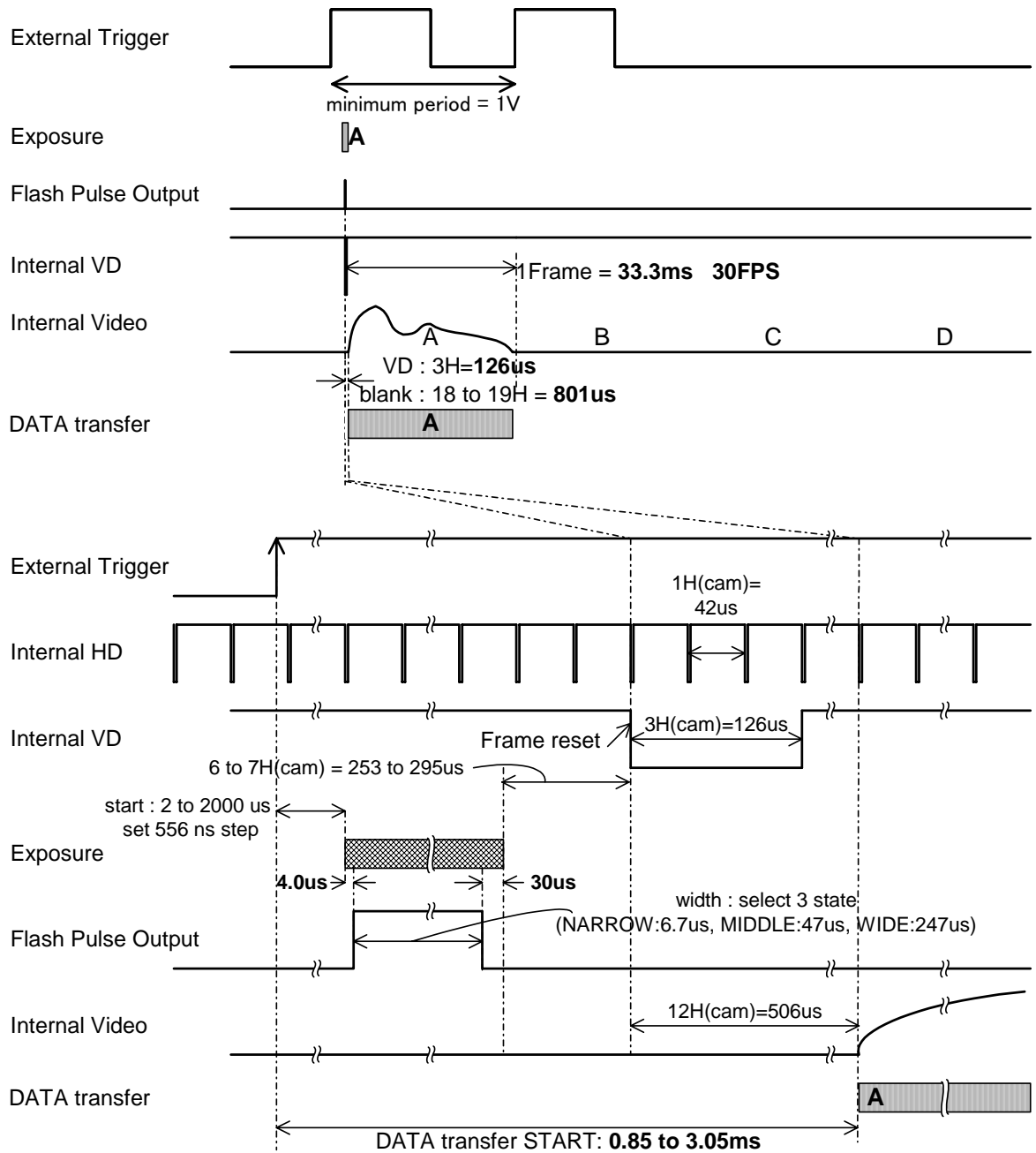

DWN	/	.	.
DSGN	/	.	.
CHKD	/	.	.
APPD	/	.	.

HV-F31CL
Color Camera
Specification (10/14)

Hitachi Kokusai Electric Inc.
Tokyo Japan

8. Main connector pin arrangements

1) Camera Link connector

Use connector: 10226-2200VE (3M) x2

Recommended cable: 14B26 series (3M)

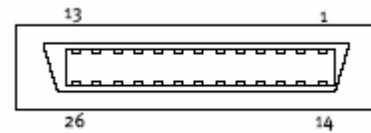
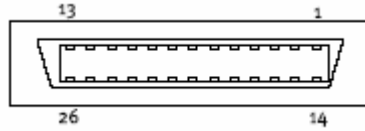

D.OUT 1 / REMOTE			D.OUT 2		
Pin	Signal Name	Function	Pin	Signal Name	Function
1	GND	Ground	1	GND	Ground
2	X0-	Video output	2	Y0-	Video output
3	X1-		3	Y1-	
4	X2-		4	Y2-	
5	Xclk-	Video clock output	5	Yclk-	Video clock output
6	X3-	Video output	6	Y3-	Video output
7	SerTC+	Serial (RXD) input	7	NC	-
8	SerTFG-	Serial (TXD) output	8	NC	-
9	NC[CC1]-	-	9	NC	-
10	NC[CC2]+	-	10	NC	-
11	NC[CC3]-	-	11	NC	-
12	NC[CC4]+	-	12	NC	-
13	GND	Ground	13	GND	Ground
14	GND	Ground	14	GND	Ground
15	X0+	Video output	15	Y0+	Video output
16	X1+		16	Y1+	
17	X2+		17	Y2+	
18	Xclk+	Video clock output	18	Yclk+	Video clock output
19	X3+	Video output	19	Y3+	Video output
20	SerTC-	Serial (RXD) input	20	NC	-
21	SerTFG+	Serial (TXD) output	21	NC	-
22	NC[CC1]+	-	22	NC	-
23	NC[CC2]-	-	23	NC	-
24	NC[CC3]+	-	24	NC	-
25	NC[CC4]-	-	25	NC	-
26	GND	Ground	26	GND	Ground

DWN
DSGN
CHKD
APPD

· ·
· ·
· ·
· ·

HV-F31CL
Color Camera
Specification (11/14)

Hitachi Kokusai Electric Inc.
Tokyo Japan

2) DC IN / SYNC connector

Use connector: HR10A-10R-12PB(01) (HIROSE) or equivalent

Matching plug: HR10A-10P-12S(01) (HIROSE) or equivalent

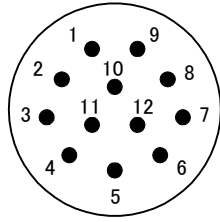

DC IN / SYNC		
Pin	Signal Name	Function
1	GND	Ground
2	+12V IN	Power supply
3	GND	Ground
4	FLASH OUT	Strobe sync signal output
5	GND	Ground
6	HD IN / TXD	External HD sync input / Camera control output ^(Note)
7	VD IN / RXD	External VD sync input / Camera control input ^(Note)
8	GND	Ground
9	TRIG (H)	Photo coupler input (Hot)
10	TRIG (C)	Photo coupler input (Cold)
11	+12V IN	Power supply
12	GND	Ground

(Note) Either external sync input or camera control input/output are selectable by internal switch.

DWN	/	.	.	HV-F31CL Color Camera Specification (12/14)	Hitachi Kokusai Electric Inc. Tokyo Japan	
DSGN	/	.	.			
CHKD	/	.	.			
APPD	/	.	.			

9. Main accessories

- 1) Power supply adapter
- 2) DC IN / SYNC cable
- 3) Camera Link cable
- 4) Junction box JU-M1A

10. Cautions in using lens

1) Lens protrusion from flange face (T)

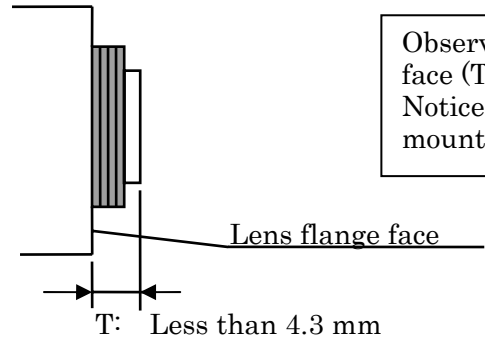

Observe the limit of lens protrusion from the flange face (T in figure).
 Notice the lens and camera can be damaged if this mounting dimension is not maintained.

T: Less than 4.3 mm

2) Choosing a lens

The proper lens is important for obtaining the best camera performance.

When choosing a lens, check with the lens maker and note the following points.

- Size should be for 1/3-inch. If too large (such as 1/2 or 2/3 inch) ghosting can appear in the scene.
- Vertical color shading can occur with a lens of short exit pupil.
- When used with the iris nearly fully open, shading and flare can detract from image quality.

DWN	/	· ·	HV-F31CL Color Camera Specification (13/14)	Hitachi Kokusai Electric Inc. Tokyo Japan	
DSGN		· ·			
CHKD		· ·			
APPD		· ·			

11. External View

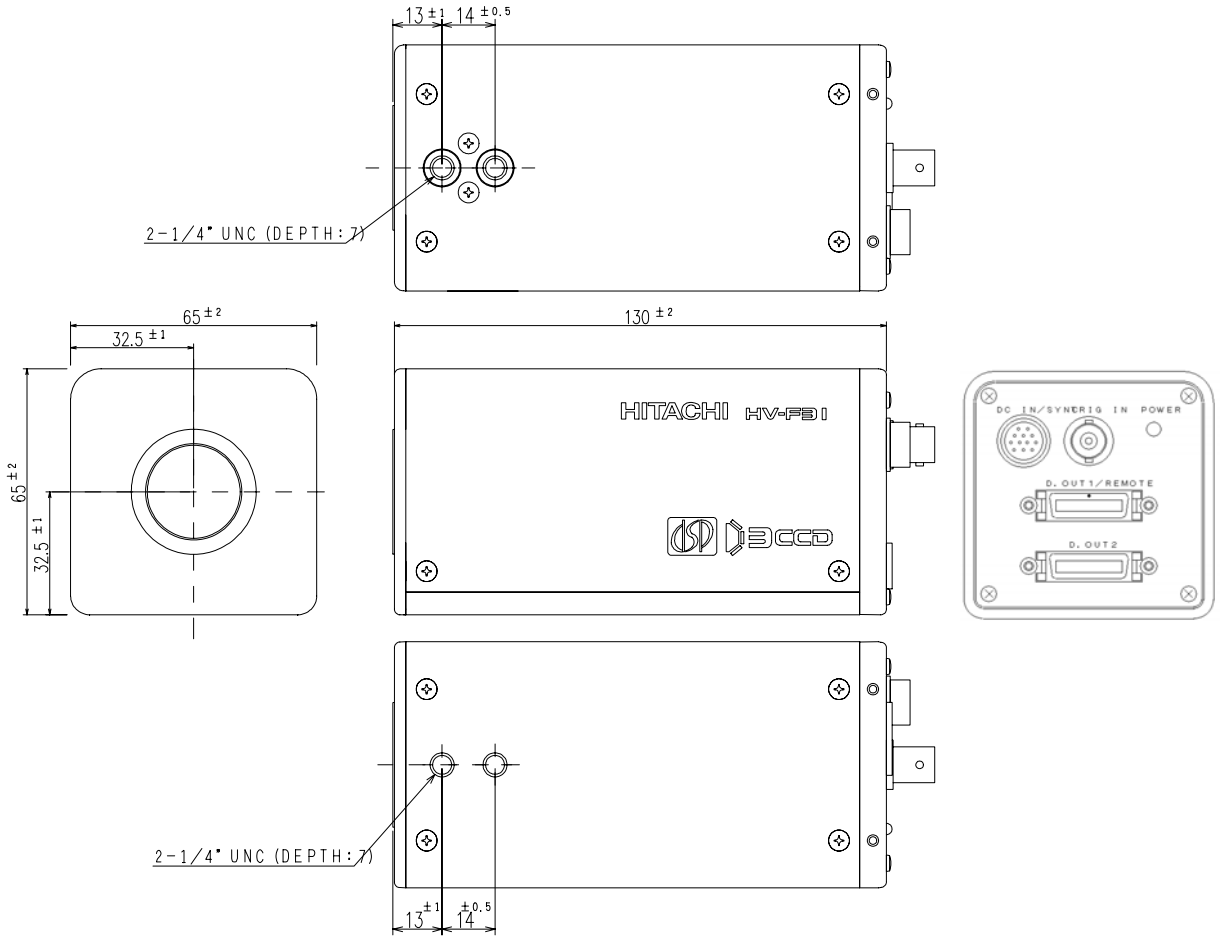

DWN	/	.	.	HV-F31CL Color Camera Specification (14/14)	Hitachi Kokusai Electric Inc. Tokyo Japan	
DSGN	/	.	.			
CHKD	/	.	.			
APPD	/	.	.			

1

2

3

A

B

C

D

E

F