

1

2

3

4

A

B

C

D

E

F

HV-D27A  
HV-D37A

Color Camera  
Tentative Specifications

DWN	K.Tanaka	Jun・6・'04	HV-D27A/HV-D37A Color Camera Tentative Specification (1/17)	Hitachi Kokusai Electric Inc Tokyo Japan	
DSGN	K.Tanaka	Jun・6・'04			
CHKD	T.Inoue	Jun・6・'04			
APPD	T.Inoue	Jun・6・'04			

1

2

3

## 1. General

HV-D27A/HV-D37A color camera is a separate type camera head utilizing three CCDs in a compact and light weight and camera control unit (CCU) system. By utilizing 410,000 pixels (470,000 pixels PAL) CCDs in addition to single LSI chip digital circuit construction from processor to encoder, both high picture quality and high stability have been achieved. CCD size is 1/2-inch for the HV-D27A and 1/3-inch for the HV-D37A.

Hitachi's extensive experience in broadcast and industrial color cameras has lead to an exclusive 14-bit digital processing technology that provides a host of important functions in a newly developed LSI device. The high quality signal processing and image compensating functions were unattainable in earlier analog cameras. The versatile C mount also allows use with a broad range of optical systems and opens up applications in a wide variety of fields, factory automation, image processing, microscope technology etc.

## 2. Features

### 1) Single chip LSI camera signal processor

Hitachi's leading edge processing technology (0.18  $\mu\text{m}$ , internal core 1.8V drive, and 3 million gates) is contained on a single newly developed ultra LSI chip. The system is compact and consumes very little power. Also, the 12-bit A/D converter and 14-bit internal processor provide high signal to noise ratio and wide dynamic range.

### 2) C mount

The camera uses a C mount lens, which is the de facto standard in the industry.

Note : Some lenses cannot be used. Check before use. See "9 when using lens".

### 3) High resolution

The 410,000 pixel (470,000 PAL) CCDs with high sensitivity microlenses are mated to prism optics using high precision matching technology. Accelerated digital luminance signal processing is used to deliver 800 TV lines (HV-D27A) / 750 TV lines (HV-D37A) horizontal resolution (luminance channel).

### 4) High S/N

A signal to noise ratio of 62 dB (60dB PAL) is attained by the new digital noise reduction system. Clear, low noise images are obtained even in the high gain mode.

### 5) High sensitivity

The +24 dB high gain mode and digital gain function provide sensitivity and low light performance 0.5lx, F1.6 (HV-D27A)/0.9lx, F2.2 (HV-D37A). When combined with the digital noise reduction system, pickup is enabled under adverse conditions that were beyond the reach of previous CCD cameras.

DWN		• •	HV-D27A/HV-D37A Color Camera Tentative Specification (2/17)	Hitachi Kokusai Electric Inc Tokyo Japan
DSGN		• •		
CHKD		• •		
APPD		•		

## 6) Digital processing enables quality enhancement functions

- Extensive experience in broadcast and industrial cameras is evidenced by the 6 vector independent variable masking, which is ideal for such applications as image processing and microscope technology where high color reproduction fidelity is essential.
- Auto knee varies the high luminosity signal compression point according to the amount of incident light. Dynamic chroma compensates for color loss in high luminosity signals. Dynamic range is expanded to bring high reproduction quality even to outdoor scenes.
- Variable detail boost frequency is also provided.

## 7) Auto shading compensation (ASC)

Color shading incurred when using a C mount lens is automatically compensated (attenuated).

Two modes of shading are provided and can be selected according to the cameras application, a vertical color shading mode or a two-dimensional luminance-shading mode.

## 8) CCD drive functions

- Preset electronic shutter mode (10 steps)
- Lockscan mode reduces flicker in images with a different scanning frequency (e.g., a scene showing a computer display screen). The fixed frequency minimizes the appearance of a horizontal bar (not effective in all cases).
- Auto electronic shutter (AES) maintains a fixed video level.
- Long term integration mode accommodates field and frame integration (needs external video memory for a continuous picture).
- Frame readout mode improves vertical resolution. (The sensitivity lower in AES mode of frame integration.)
- Field on demand produces an image in response to an external trigger signal. (needs external video memory for a continuous picture).

## 9) Versatile pickup functions

- Four scene files  
Detail, masking, knee and other settings can be customized.
- Real time automatic white balance adjustment. The variable detector gate function can be utilized to avoid white balance disruption even if a light source having a different color temperature enters the scene.
- Intelligent ALC (auto level control)  
The digital light meter and CPU processing provide continuous digital control of AGC, lens iris and auto electronic shutter over an extremely wide variation in lighting. The ALC level can be fine adjusted and the response selected for peak or average from the menu.  
(Combining with AES is effective only with a manual override lens.)
- Full auto mode
- AGC and 1 step programmable gain switch

DWN		• •	HV-D27A/HV-D37A Color Camera Tentative Specification (3/17)	Hitachi Kokusai Electric Inc Tokyo Japan	
DSGN		• •			
CHKD		• •			
APPD		• •			

- Contrast function
- Flare compensation circuit
- Variable chroma level
- Variable master black, R/B black, R/B gain
- Monochrome mode
- Color bar
- Title display
- Negative/positive selection
- Focus data output (Serial data output via RS-232C)

10) Bi-directional data transfer

A personal computer can be connected directly (RS-232C) for remotely controlling the camera functions. Conversely, the camera mode data are sent to the computer to allow very precise camera control. In multiple camera systems, each camera can be assigned an ID number to enable controlling multiple cameras from a single computer.

11) Switchable video signal outputs

The output can be selected for VBS, Y/C, RGB, Y/R-Y/B-Y according to the application.

3. Standard composition

3-1. Camera(HV-D27A/HV-D27A)	.....	1
3-2. Accessories		
1) Lens mount sheet	.....	1
2) Power supply plug (R03-P3F)	.....	1
3) Operation manual	.....	1

DWN	/	• •	HV-D27A/HV-D37A Color Camera Tentative Specification (4/17)	Hitachi Kokusai Electric Inc Tokyo Japan	
DSGN	/	• •			
CHKD	/	• •			
APPD	/	•			

A

B

C

D

E

F

	1	2	3	4
4. Specifications				
1) Color system		NTSC, PAL		A
2) Optical system		HV-D27A: 1/2-inch, F1.6 prism HV-D37A: 1/3-inch, F2.2 prism		
3) Imaging system		R, G, B 3 CCD		
4) Picture elements		HV-D27A: 1/2-inch interline transfer CCD HV-D37A: 1/3-inch interline transfer CCD (with microlenses)		
Total pixels		NTSC 811 (H) × 508 (V) PAL 795 (H) × 596 (V)		B
Effective pixels		NTSC 768 (H) × 494 (V) PAL 752 (H) × 582 (V)		
Effective image area		HV-D27A: NTSC 6.34 (H) × 4.76 (V) mm PAL 6.35 (H) × 4.78(V) mm HV-D37A: NTSC 4.79 (H) × 3.60 (V) mm PAL 4.80 (H) × 3.60(V) mm		
5) Scanning system		2:1 interlace		
6) Scanning frequency		NTSC 15.735 kHz (H) × 59.94 Hz (V) PAL 15.634 kHz (H) × 50.00 Hz (V)		C
7) Encoder system		R-Y/B-Y		
8) Sync system		Internal/external (VBS, BBS or HD/VD auto selection, when internal input/output switch is input position)		
9) Horizontal resolution		HV-D27A: 800 TV lines, luminance signal center HV-D37A: 750 TV lines, luminance signal center (Y out and DTL off)		
10) S/N		HV-D27A: NTSC 62 dB type (DNR on), 59 dB type (DNR off) PAL 60 dB type (DNR on), 57 dB type (DNR off) (Y out, $\gamma=1$ , DTL off, GAIN 0 dB)		D
11) Standard sensitivity		2000 lx, F11		
12) Minimum illumination		HV-D27A: 0.5 lx (50IRE F1.6) HV-D37A: 0.9 lx (50% F2.2) (GAIN +24 dB, DIGITAL GAIN +12 dB)		
13) Gamma correction		0.45/1.0 (on/off)		
14) Geometric distortion		Full screen 0% (not including lens characteristics)		E
15) Registration		Full screen 0.05% (not including lens characteristics)		
16) Vertical contour compensation		2H		
DWN		• •	HV-D27A/HV-D37A	
DSGN		• •	Color Camera	
CHKD		• •	Tentative	
APPD		• •	Specification	
			(5/17)	
			Hitachi Kokusai Electric Inc	F
			Tokyo Japan	

	1	2	3	4
17) Lens mount		C mount (flangeback 17.526 mm in air)		
18) Sensitivity selection		AGC (0 to +24 dB) or GAIN (0 to +24 dB step 1dB or step 3 dB on remote control menu)		A
19) Detail control		DTL level and frequency		
20) Scene files		4 Files		
21) Digital gain		+6 dB, +12 dB sensitivity increase by digital signal processing		
22) CCD drive functions				
Preset:		1/100 (1/60 PAL), 1/250, 1/500, 1/1000, 1/2000, 1/4000, 1/10,000 1/20,000 1/40,000 1/100,000second		B
Lockscan:		NTSC 1/60.38 to 1/2039 second (step 1H), to 1/100,000 second (step approx. 10% video level) PAL 1/50.31 to 1/2024 second (step 1H) to 1/100,000 second (step approx. 10% video level)		
AES:		Off to approx. 1/100,000 second		
Long term integration:		Field/frame integration selectable		
Field integration		NTSC 1/30 to approx. 4 seconds (1 frame steps) PAL 1/25 to approx. 4 seconds (1 frame steps)		C
Frame integration		NTSC 1/30 to approx. 8 seconds (1 frame steps) PAL 1/25 to approx. 8 seconds (1 frame steps) (external image memory needed for continuous image)		
Frame readout		improves vertical resolution (residual image response deterioration)		
23) Color bar		NTSC: SMPTE, PAL: Full		
24) Power supply voltage		12 V rated (Stable operation at 10.5 to 15 VDC (ripple and noise absent))		D
25) Power consumption		Approx. 6.5 W		
26) Dimensions		HEAD: 38.5(W)×46(H)×42(D)mm CCU: 150(W)×45(H)×170(D)mm		
27) Mass		HEAD: Approx. 90 g (not including lens) CCU: Approx. 950g		
28) Ambient temperature		Operating 0 to 45 °C Storage -20 to 60 °C		E
DWN		• •	HV-D27A/HV-D37A	
DSGN		• •	Color Camera	Hitachi Kokusai Electric Inc
CHKD		• •	Tentative	Tokyo Japan
APPD		• •	Specification (6/17)	

## 5. Input and output signals

### 5-1. Input signal conditions

#### 1) Genlock input (MULTI connector)

- VBS 1.0 Vp-p  $\pm$ 3 dB or black burst/75  $\Omega$  or high (BNC)  
(sync 0.3  $\pm$ 0.1 Vp-p, burst 0.3  $\pm$ 0.1 Vp-p)
- HD/VD 2 to 5 Vp-p, negative (D-sub connector)

Note: Genlock input and Sync output are selected by internal input/output switch.

#### 2) External trigger input (MULTI connector)

Ext Trig Low 0 VDC, High 2 to 5 VDC

#### 3) Serial data (REMOTE connector)

1.5 Vp-p  $\pm$ 3 dB/High (when connected to RC-Z3, JU-C20, JU-Z2)  
RS-232C level (when connected to personal computer)

Note: Set internal switches according to connected equipment.)

A level converter JU-C20 is required if controlling the camera from a personal computer via RS-232C interface over a distance more than approx.15 meter.

### 5-2. Output signal ratings

#### 1) Component video output (VIDEO, MULTI connector)

VBS 1.0 Vp-p/75  $\Omega$

#### 2) Y/C output (Y/C connector, MULTI connector)

Y: 1.0 Vp-p/75  $\Omega$   
C: NTSC 0.286 Vp-p (burst)/75  $\Omega$   
PAL 0.3 Vp-p (burst)/75  $\Omega$

#### 3) Component output (MULTI connector)

Y: 1.0 Vp-p/75  $\Omega$   
R-Y/B-Y: 0.7 Vp-p/75  $\Omega$

#### 4) RGB output (MULTI connector)

RGB: 0.7 Vp-p/75  $\Omega$

Note: YC/VBS, component and RGB MULTI connector outputs are selected by menu.

#### 5) Sync outputs (MULTI connector)

HD/VD: 2 Vp-p/75  $\Omega$   
Sync: 2 Vp-p/75  $\Omega$

Note: Genlock input and Sync output are selected by internal input/output switch.

#### 6) Serial data output (REMOTE connector)

1.5 Vp-p/Low (when connected to RC-Z3, JU-C2-, JU-Z2)  
RS-232C level (when connected to personal computer)

Note: Set internal switches according to connected equipment.)

DWN	/	• •	HV-D27A/HV-D37A Color Camera Tentative Specification (7/17)	Hitachi Kokusai Electric Inc Tokyo Japan	
DSGN		• •			
CHKD		• •			
APPD		•			

1 2 3 4

6. External trigger signal timing

6-1. Pulse width control

1) Field on Demand (SHUTTER : EXT TRIG, EXT TRIG : MODE1, CCD MODE : FIELD)

The exposure time is controlled by external trigger pulse width. One field of the picture is obtained after SYNC reset. However, the exposure time must not be below 1/1,000s, even the minimum trigger pulse width.

The diagram illustrates the timing relationship between various signals for NTSC and PAL video standards. Key signals include EXT TRIGGER, V.SYNC, SHUTTER PULSE, READOUT PULSE, EXPOSURE TIME, VIDEO OUT, WE PULSE, and HD. Annotations specify that the external trigger pulse width must be 'more than 64 μs' and that the exposure time is calculated as 'TRIG. PULSE WIDTH + MAX 64 μs'. For NTSC, the video output duration is 'NTSC:20H' and the shutter reset delay is '2 to 3H'. For PAL, the video output duration is 'PAL :25H' and the shutter reset delay is '2.5 to 3.5H'. The diagram is divided into sections A through F.

DWN		· ·	HV-D27A/HV-D37A Color Camera Tentative Specification (8/17)	Hitachi Kokusai Electric Inc Tokyo Japan	
DSGN		· ·			
CHKD		· ·			
APPD		· ·			

1 2 3

2) Frame on demand (SHUTTER : EXT TRIG, EXT TRIG : MODE1, CCD MODE : FRAME)

When an external flash trigger signal is applied, the V SYNC is reset and one frame of the picture is obtained. The exposure time is controlled by the external trigger pulse width and SYNC reset timing. Also, the SYNC reset timing from the flash timing can be adjusted by the camera menu setting.

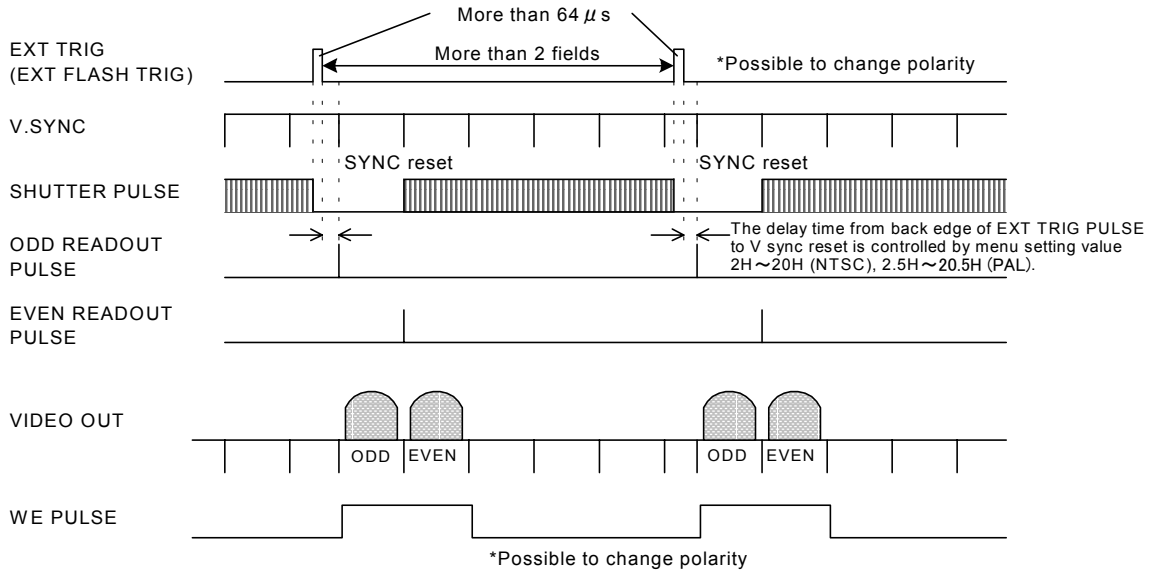

Note: When the flashlight is not used, the even and odd video signal levels are difference as shown to the following timing chart.

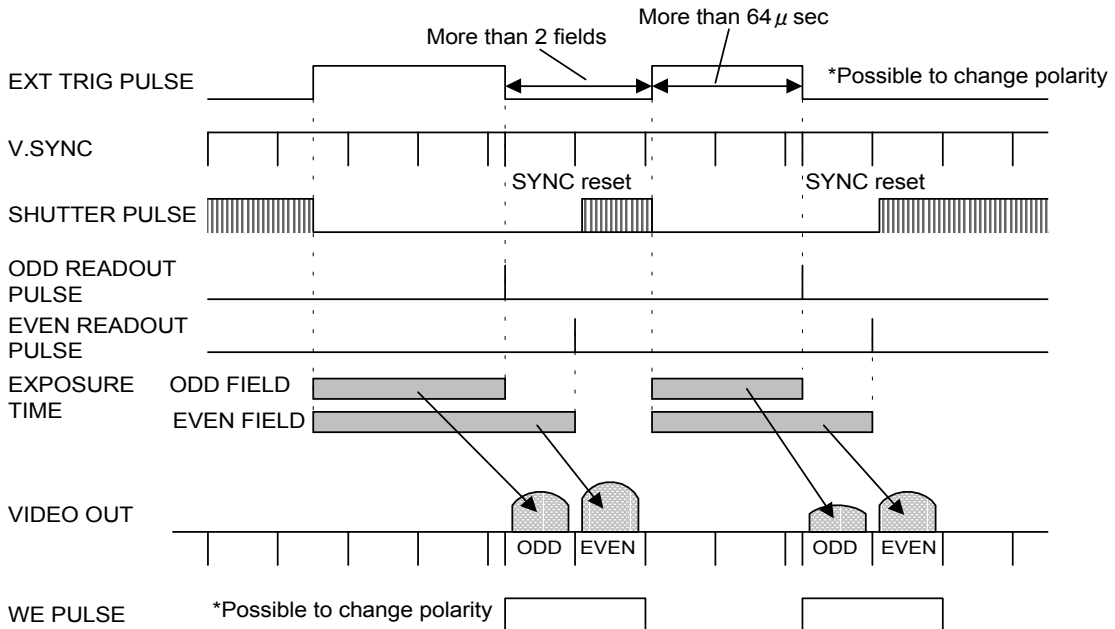

DWN	/	• •
DSGN		• •
CHKD		• •
APPD		• •

HV-D27A/HV-D37A  
Color Camera  
Tentative  
Specification  
(9/17)

Hitachi Kokusai Electric Inc  
Tokyo Japan

1 2 3 4

6-2. Long integration mode

(1) Field mode (SHUTTER : EXT TRIG, EXT TRIG : MODE2, CCD MODE : FIELD)

The trigger pulse width and the timing of external trigger pulse against the camera SYNC control the exposure time. One field of the picture is obtained at first ODD field after the back edge of external trigger pulse.

EXT TRIG: A pulse with a width labeled "More than 2 fields". Below it, "Sync reset (2 to 3H delay (NTSC), 2.5 to 3.5H delay (PAL))" is indicated. A note says "\*Possible to change polarity".

V.SYNC: A sequence of fields labeled EVEN, ODD, EVEN, ODD, followed by a blank space, then ODD, EVEN, ODD, EVEN.

READOUT PULSE: A series of pulses corresponding to the V.SYNC fields.

EXPOSURE TIME: A shaded bar representing the exposure duration. A note indicates: "TRIG PULSE WIDTH - 1V ≤ EXPOSURE TIME ≤ TRIG PULSE WIDTH + 2 to 3H (NTSC), 2.5 to 3.5H (PAL)".

VIDEO OUT: A sequence of video frames labeled ODD, EVEN, ODD, EVEN, followed by a blank space, then ODD, EVEN, ODD, EVEN, ODD. The first ODD field after the trigger pulse is shaded to indicate the start of the picture.

WE PULSE: A pulse with a note "\*Possible to change polarity".

(2) Frame mode (SHUTTER : EXT TRIG, EXT TRIG : MODE1, CCD MODE : FRAME)

The trigger pulse width and the timing of external trigger pulse against the camera SYNC control the exposure time. One frame of the picture is obtained at first ODD field after the back edge of external trigger pulse.

EXT TRIG: A pulse with a width labeled "More than 2 fields". Below it, "Sync reset (2 to 3H delay (NTSC), 2.5 to 3.5H delay)" is indicated. A note says "\*Possible to change polarity".

V.SYNC: A sequence of fields labeled ODD, EVEN, ODD, EVEN, ODD, EVEN, followed by a blank space, then ODD, EVEN, ODD, EVEN, ODD.

EVEN READOUT PULSE: A series of pulses corresponding to the V.SYNC fields.

ODD READOUT PULSE: A series of pulses corresponding to the V.SYNC fields.

EXPOSURE TIME: Two shaded bars. The top one is labeled "ODD FIELD" and the bottom one is labeled "EVEN FIELD". A note indicates: "TRIG PULSE WIDTH - 2V ≤ EXPOSURE TIME ≤ TRIG PULSE WIDTH + 2 to 3H (NTSC), 2.5 to 3.5H (PAL)".

VIDEO OUT: A sequence of video frames labeled ODD, EVEN, ODD, EVEN, ODD, EVEN, followed by a blank space, then ODD, EVEN, ODD, EVEN, ODD. The first ODD field after the trigger pulse is shaded to indicate the start of the picture.

WE PULSE: A pulse with a note "\*Possible to change polarity".

DWN		• •	HV-D27A/HV-D37A Color Camera Tentative Specification (10/17)	Hitachi Kokusai Electric Inc Tokyo Japan
DSGN		• •		
CHKD		• •		
APPD		• •		

1 2 3

Note: For each external trigger mode, when the end edge of external trigger pulse is input in the timing period when it showed to the under figure, the picture is not output after the SYNC reset. Please input the repetition period of trigger pulse with the following specification, to avoid the trigger input to an above prohibition period.

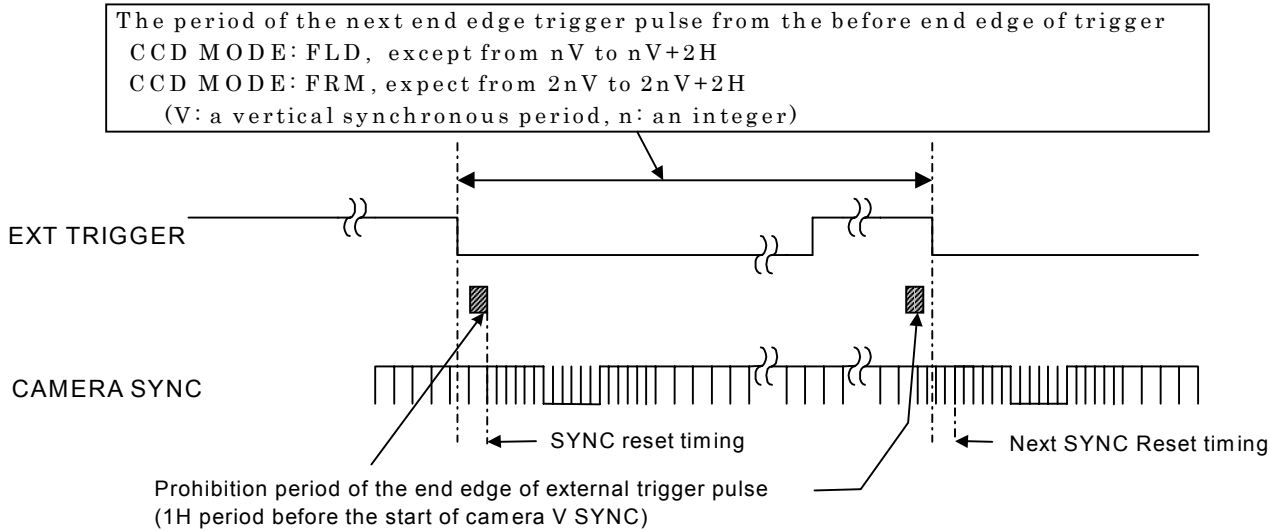

A

B

C

D

E

F

DWN	/	..	HV-D27A/HV-D37A Color Camera Tentative Specification (11/17)	Hitachi Kokusai Electric Inc Tokyo Japan	
DSGN		..			
CHKD		..			
APPD		..			

## 7. Connectors

(1) MULTI connector  
(SDEB-9S)

Pin No	Signal
1	GND
2	WE
3	R OUT
4	G OUT
5	B OUT
6	VBS OUT
7	SYNC OUT
8	RESERVE
9	RESERVE

(2) REMOTE connector  
(HR10A-7R-4S) (Plug: HR10A-7P-4P)

Pin No	Signal
1	UNREG +12V OUT
2	RXD/SD IN
3	TXD/SD OUT
4	GND

(3) 12VIN connector

(R03-R3M2) (Plug: R03-P3F)

Pin No	Signal
A	GND
B	UNREG +12V IN
C	NC

(4) TRIG connector

(HR10A-10R-12PB)

Pin No	Signal
1	GND
2	
3	
4	
5	GND
6	HD IN
7	VD/TRIG IN
8	
9	
10	GND
11	
12	GND

(5) Y/C connector

(TCS-7547-01-401)

Pin No	Signal
1	Y GND
2	C GND
3	Y OUT
4	C OUT

DWN	/	• •	HV-D27A/HV-D37A Color Camera Tentative Specification (12/17)	Hitachi Kokusai Electric Inc Tokyo Japan	
DSGN		• •			
CHKD		• •			
APPD		• •			

8. Major accessories

- 1) Camera control box RC-Z3
- 2) RS-232C level converter JU-C20, JU-Z2

9 when using lens

- 1) Projection (T) from flange face to rear of lens

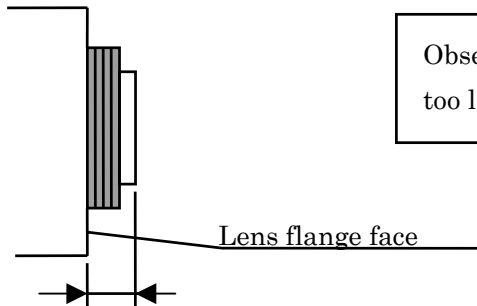

Observe the lens mount size limit indicated in the figure. If too large, the lens and camera can be damaged

T: HV-D27A: Less than 3.8 mm  
 HV-D37A: Less than 4.3 mm

- 2) Selecting lens

Overall camera lens make performance is largely affected by the lens. It is recommended to check the following points beforehand.

- Ghosting can occur by using a lens with a large image area (e.g. 2/3 or 1/2 inch for HV-D37A). Use a 1/2 inch lens for HV-D27A and 1/3 inch lens for HV-D37A.
- Vertical color shading can occur if the lens has a short exit pupil length.
- If the lens is used at nearly fully open iris, resolution is sacrificed, while such problems as shading and flare can detract from the image quality.

DWN	/	• •	HV-D27A/HV-D37A Color Camera Tentative Specification (13/17)	Hitachi Kokusai Electric Inc Tokyo Japan	
DSGN		• •			
CHKD		• •			
APPD		•			

10.Exploded view

(1) HV-D27A HEAD

• MASS : APPROX. 90 g  
 • COLOR : GRAY  
 • UNIT : mm

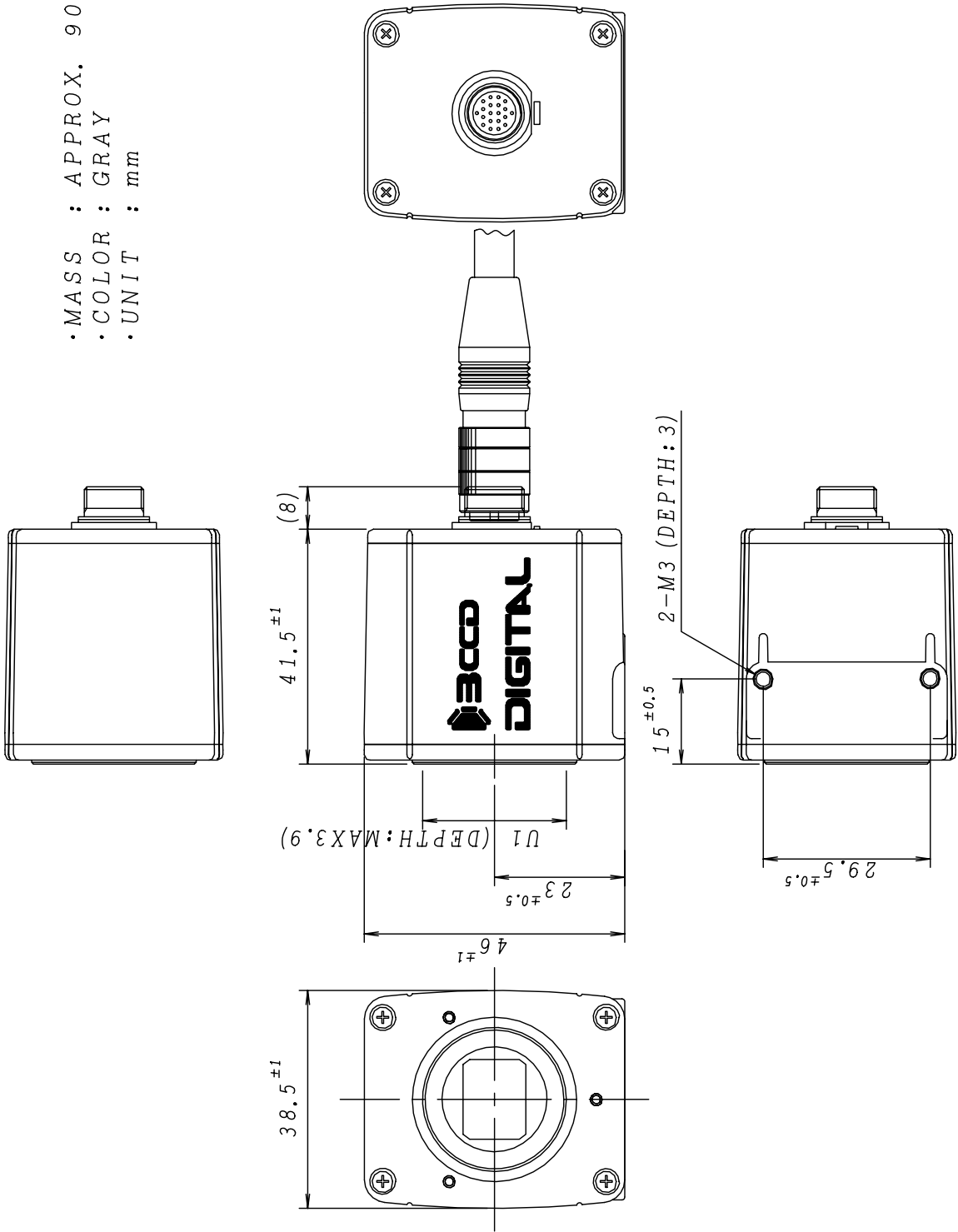

DWN	/	/	• •
DSGN			• •
CHKD			• •
APPD			• •

Hitachi Kokusai Electric Inc  
 Tokyo Japan

1 2 3 4

A  
B  
C  
D  
E  
F

1 2 3

(2)HV-D37A HEAD

•MASS : APPROX. 90g  
 •COLOR : GRAY  
 •UNIT : mm

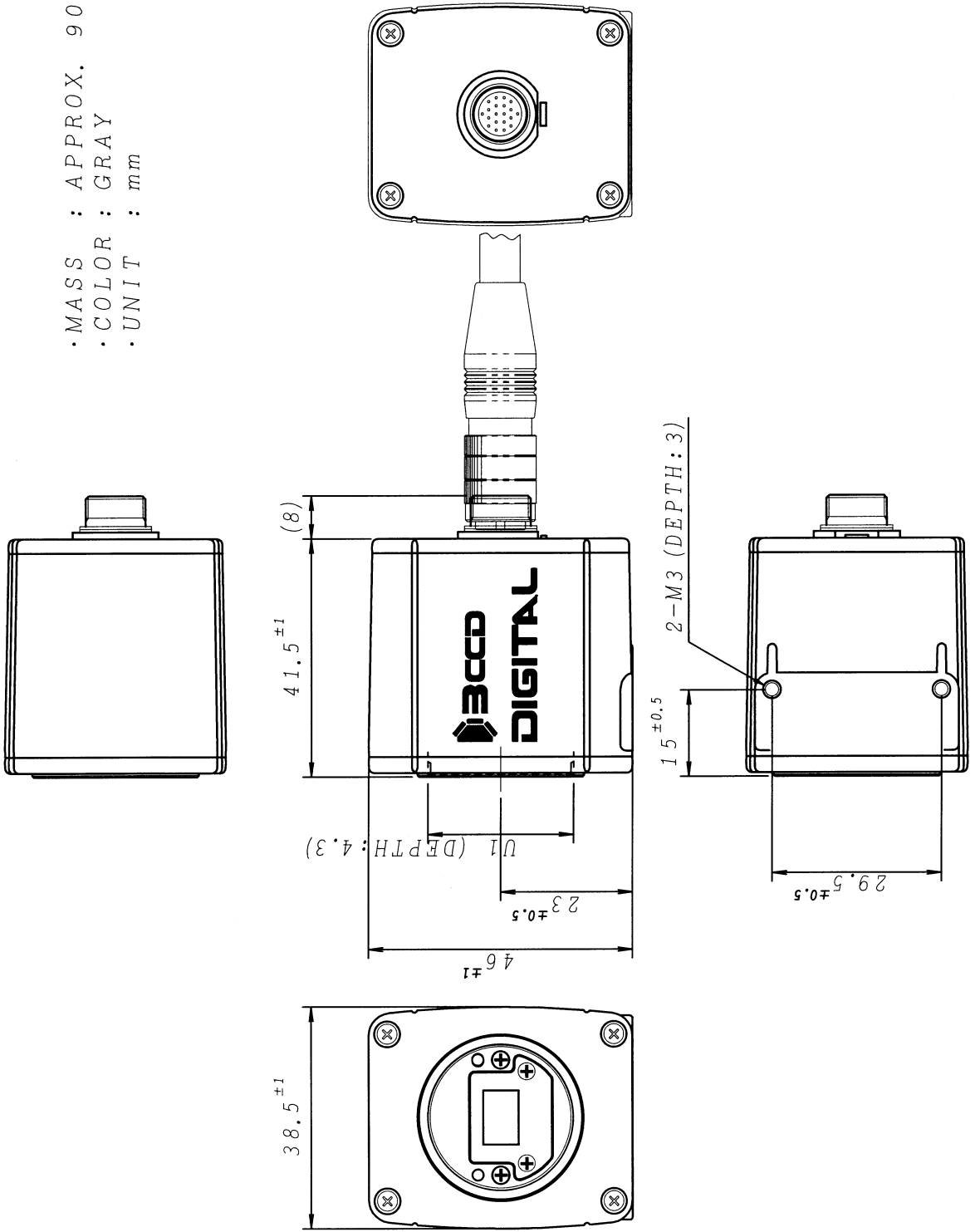

DWN	/	••
DSGN		••
CHKD		••
APPD		••

Hitachi Kokusai Electric Inc  
 Tokyo Japan

(3) CCU

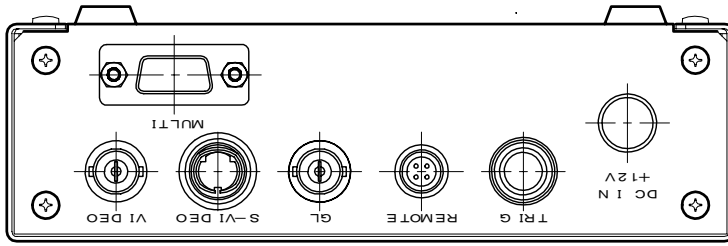

MASS: APPROX. 950 g

UNIT: mm

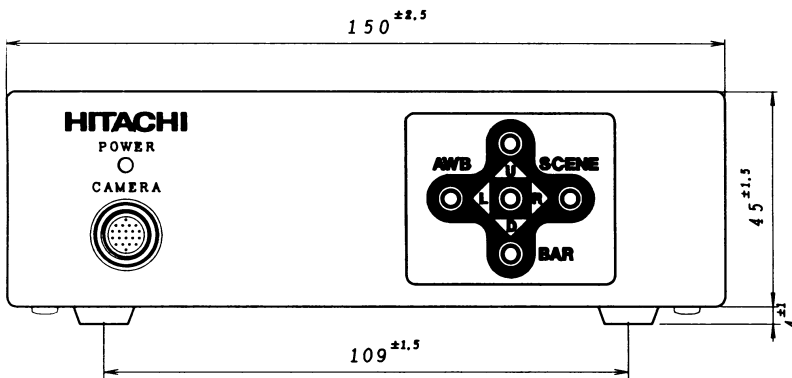
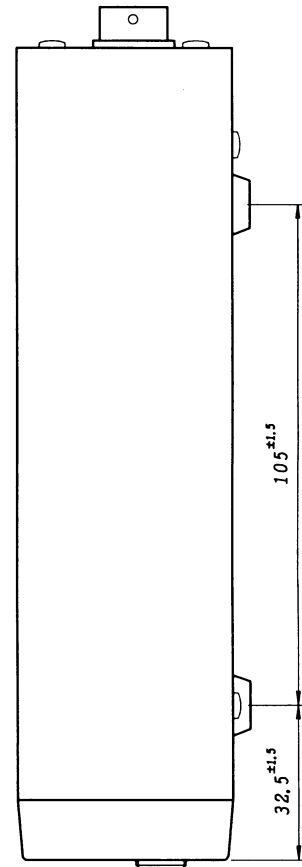
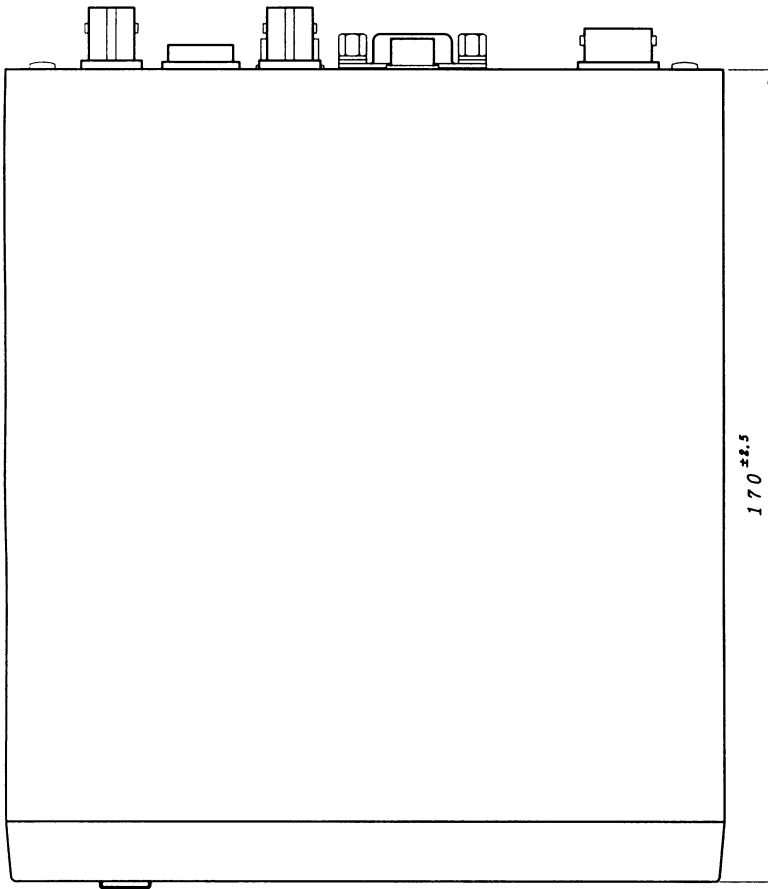

DWN	/	• •
DSGN		• •
CHKD		• •
APPD		• •

Hitachi Kokusai Electric Inc  
Tokyo Japan

1 2 3 4

A

B

C

D

E

F

1

2

3

11. System example

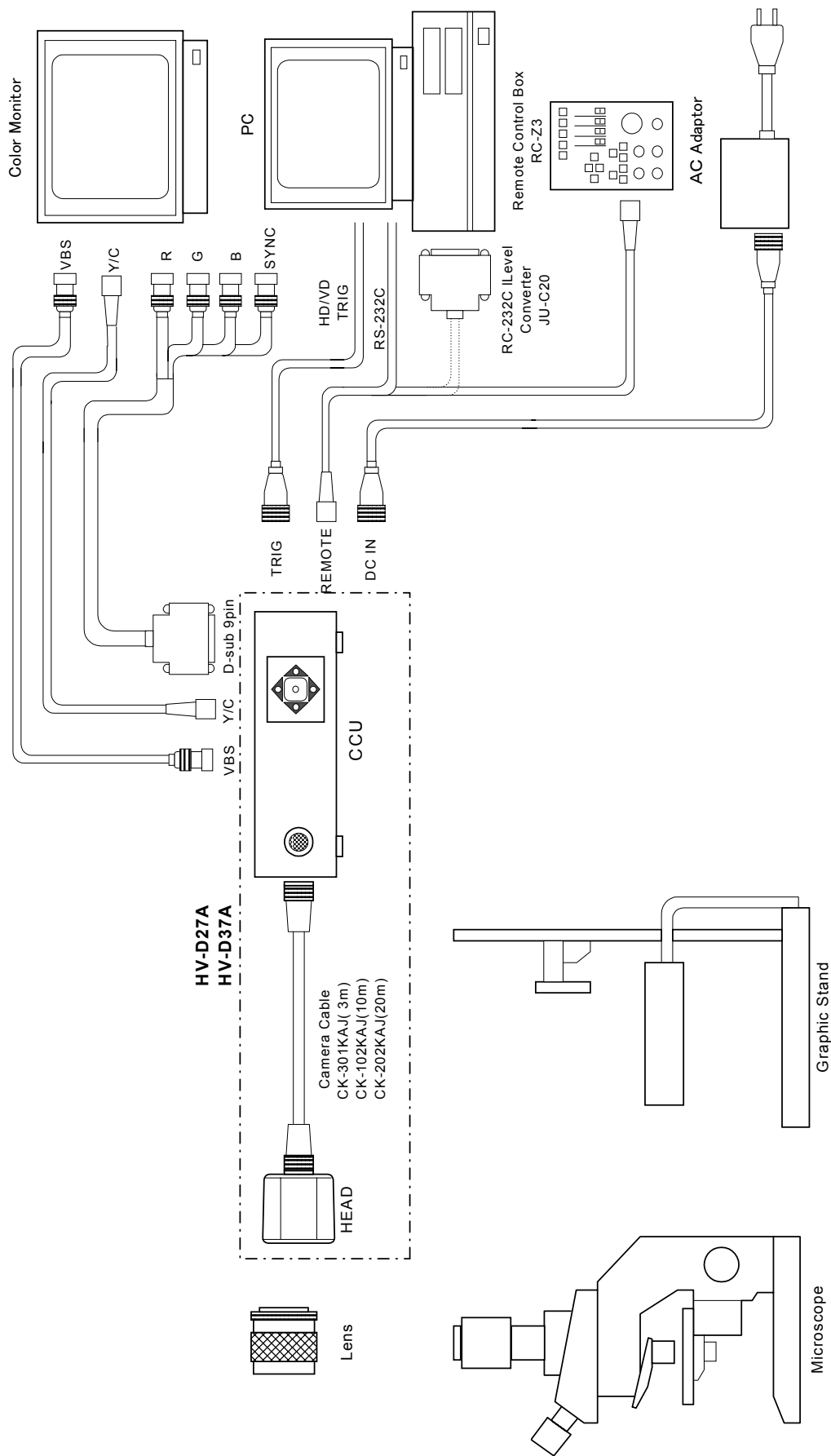

DWN			• •
DSGN			• •
CHKD			• •
APPD			• •

Hitachi Kokusai Electric Inc  
Tokyo Japan